



Commercial Side Table Refrigerator & Freezer Service Manual



TABLE OF CONTENTS

1. SPECIFICATIONS	4
2. PARTS	5~38
3. WIRING DIAGRAM	39~40
4. ELECTRONIC CONTROL INSTRUCTIONS	41~ 60
5. PART LIST	61

Safety cautions during service



- **When exchanging or repairing electric parts, pull the plug out before exchanging and repairing.**
- **When exchanging electric parts, use a rating part.**
 - Be sure to check marks such as MODEL name, rating voltage, rating currents, movement temperature etc.
- **During repairing, make sure wirings such as HARNESS, WIRE JOINT are sturdy so that it is free of danger due to disclosure of core wire.**
 - Don't let it derail when certain strength is put on.
- **When repairing, take out the dust or foreign body (Housing part, wiring part, contact point part).**
 - It prevents danger of fire such as TRACKING, SHORT.
- **Check whether water has gone into the electric parts.**
 - When there are traces of water, exchange the parts or enact the TRACKING prevention device.
- **After repairing, check the assembly status of the parts.**
 - Keep the status as it was before the repairing. .
- **After checking the usage environment of the product and if the installation is unstable, change the usage location.**
 - For installations in places with moisture, water and for heat devices, prevent placing products near igniting materials etc.
- **When earthing is needed, earth it.**
 - For cases when electric leakage is concerned due to moisture or water, be sure to earth it.
- **For products that consumes power such as electric products, make sure numerous plugs are not used in a single outlet.**

1.Specifications

A. Dimensions(Unit : mm)

Model	A	B	C	Model	A	B	C	Model	A	B	C	Model	A	B	C
LNRT-1B-900	900	510	700	LERT-1B-900	900	510	700	LGRT-1B-900	900	510	700	LNRT-1A-900	900	510	600
LNRT-1B-900L	900	510	700	LERT-1B-900L	900	510	700	LGRT-1B-900L	900	510	700	LNRT-2A-1200	1200	353	600
LNRT-2B-1200	1200	353	700	LERT-2B-1200	1200	353	700	LGRT-2B-1200	1200	353	700	LNRT-2A-1500	1500	505	600
LNRT-2B-1500	1500	505	700	LERT-2B-1500	1500	505	700	LGRT-2B-1500	1500	505	700	LNRT-3A-1800	1800	400.7	600
LNRT-3B-1800	1800	400.7	700	LERT-3B-1800	1800	400.7	700	LGRT-3B-1800	1800	400.7	700	LNFT-1A-900	900	510	600
LNFT-1B-900	900	510	700	LEFT-1B-900	900	510	700	LGRT-1C-900	900	510	750	LNFT-2A-1200	1200	353	600
LNFT-1B-900L	900	510	700	LEFT-1B-900L	900	510	700	LGRT-1C-900L	900	510	750	LNFT-2A-1500	1500	505	600
LNFT-2B-1200	1200	353	700	LEFT-2B-1200	1200	353	700	LGRT-2C-1200	1200	353	750	LNFT-3A-1800	1800	400.7	600
LNFT-2B-1500	1500	505	700	LEFT-2B-1500	1500	505	700	LGRT-2C-1500	1500	505	750				
LNFT-3B-1800	1800	400.7	700	LEFT-3B-1800	1800	400.7	700	LGRT-3C-1800	1800	400.7	750				
LNFT-1C-900	900	510	750	LEFT-1C-900	900	510	750	LEGRT-1B-900	900	510	700				
LNFT-1C-900L	900	510	750	LEFT-1C-900L	900	510	750	LEGRT-1B-900L	900	510	700				
LNRT-1C-900L	900	510	750	LERT-1C-900L	900	510	750	LEGRT-2B-1200	1200	353	700				
LNRT-2C-1200	1200	353	750	LERT-2C-1200	1200	353	750	LEGRT-2B-1500	1500	505	700				
LNRT-2C-1500	1500	505	750	LERT-2C-1500	1500	505	750	LEGRT-3B-1800	1800	400.7	700				
LNRT-3C-1800	1800	400.7	750	LERT-3C-1800	1800	400.7	750	LEGRT-1C-900	900	510	750				
LNFT-1C-900	900	510	750	LEFT-1C-900	900	510	750	LEGRT-1C-900L	900	510	750				
LNFT-1C-900L	900	510	750	LEFT-1C-900L	900	510	750	LEGRT-2C-1200	1200	353	750				
LNFT-2C-1200	1200	353	750	LEFT-2C-1200	1200	353	750	LEGRT-2C-1500	1500	505	750				
LNFT-2C-1500	1500	505	750	LEFT-2C-1500	1500	505	750	LEGRT-3C-1800	1800	400.7	750				
LNFT-3C-1800	1800	400.7	750	LEFT-3C-1800	1800	400.7	750								

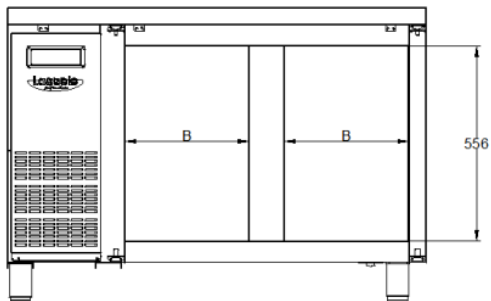
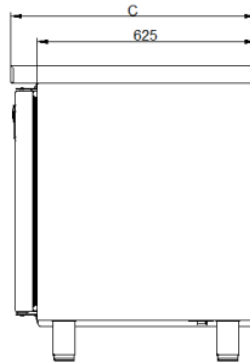
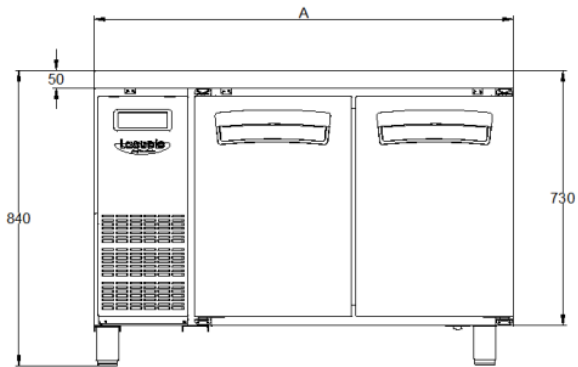

2. PART

A. MainAssembly

a.LNRT-1B/1C-900/900L, LERT-1B/1C-900/900L

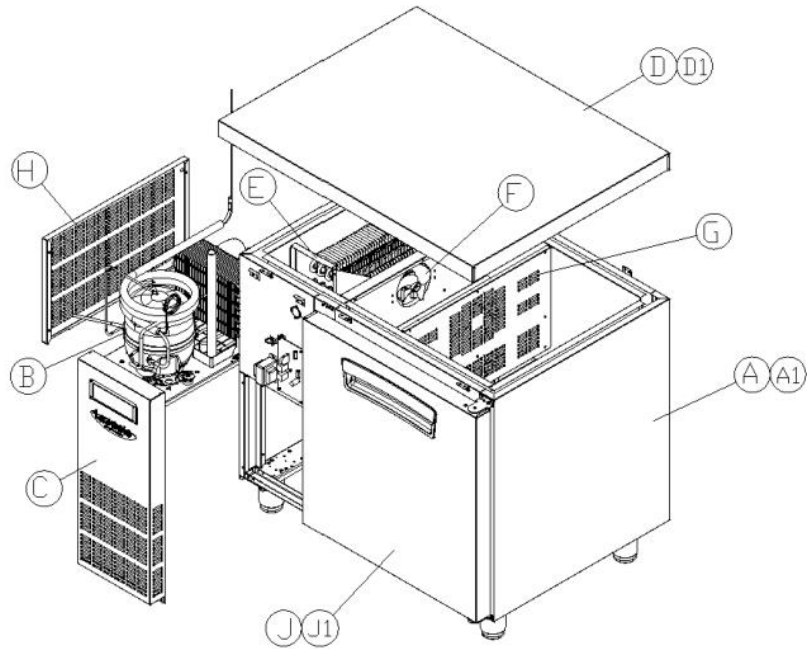

NO	Code No	Description	Qty	Material	Spec
A	R810B-990	ASSY INNER CASE(1B-900)	1	-	LNRT-1B-900
A1	R810C-490	ASSYINNER CASE(W900)_GN	1	-	LERT-1B-900
B	R815A-520	ASSY UNIT(SK170Q-L1U)	1	-	SK170Q-L1U
C	R858E-290	COVER FRONT AS(TABLE)	1	-	TABLE
D	R875A-440	ASSY TABLE TOP(1B-900)	1		LNRT-1B-900
D1	R875A-070	ASSY TABLE TOP(1C-900)	1		LNRT-1C-900
E	R214A-110	EVAPORATOR REF	1	AL	
F	R840A-170	ASSY EVA 1M(D700)	1	-	-
G	R325A-900	COVER EVA D700(1M)	1	STS443CT 2B	T0.5*522*318.2
H	R325B-030	COVER SIDE(D700)	1	STS430 #4	T0.5*603.2*345
J	R817C-170	ASSY DOOR RH(W900)	1		LNRT-1B-900
J1	R817C-160	ASSY DOOR LF(W900)	1		LNRT-1B-900L

b.LNRT-2B/2C-1200, LERT-2B/2C-1200

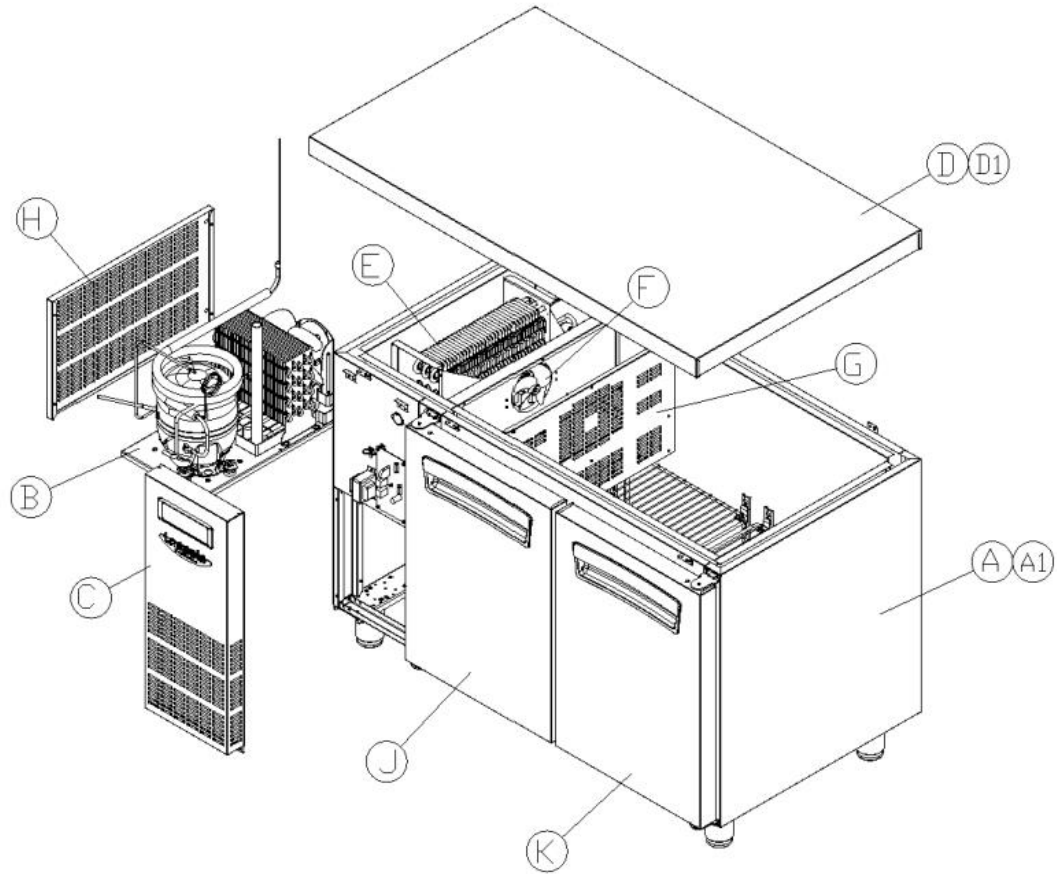

NO	Code No	Description	Qty	Material	Spec
A	R814B-240	ASSY CABI PRE(2B-1200)	1	-	LNRT-2B-1200
A1	R814B-790	ASSY CABI PRE(W1200)_GN	1	-	LERT-2B-1200
B	R815A-520	ASSY UNIT(SK170Q-L1U)	1	-	SK170Q-L1U
C	R858E-290	COVER FRONT AS(TABLE)	1	-	TABLE
D	R875A-450	ASSY TABLE TOP(2B-1200)	1		LNRT-2B-1200
D1	R875A-100	ASSY TABLE TOP(2C-1200)	1		LNRT-2C-1200
E	R214A-110	EVAPORATOR REF	1	AL	
F	R840A-170	ASSY EVA 1M(D700)	1	-	-
G	R325A-900	COVER EVA D700(1M)	1	STS443CT 2B	T0.5*522*318.2
H	R325B-030	COVER SIDE(D700)	1	STS430 #4	T0.5*603.2*345
J	R817B-860	ASSY DOOR LF(W1200)	1		LNRT-2B-1200
K	R817B-890	ASSY DOOR RH(W1200)	1		LNRT-2B-1200

c.LNRT-2B/2C-1500, LERT-2B/2C-1500

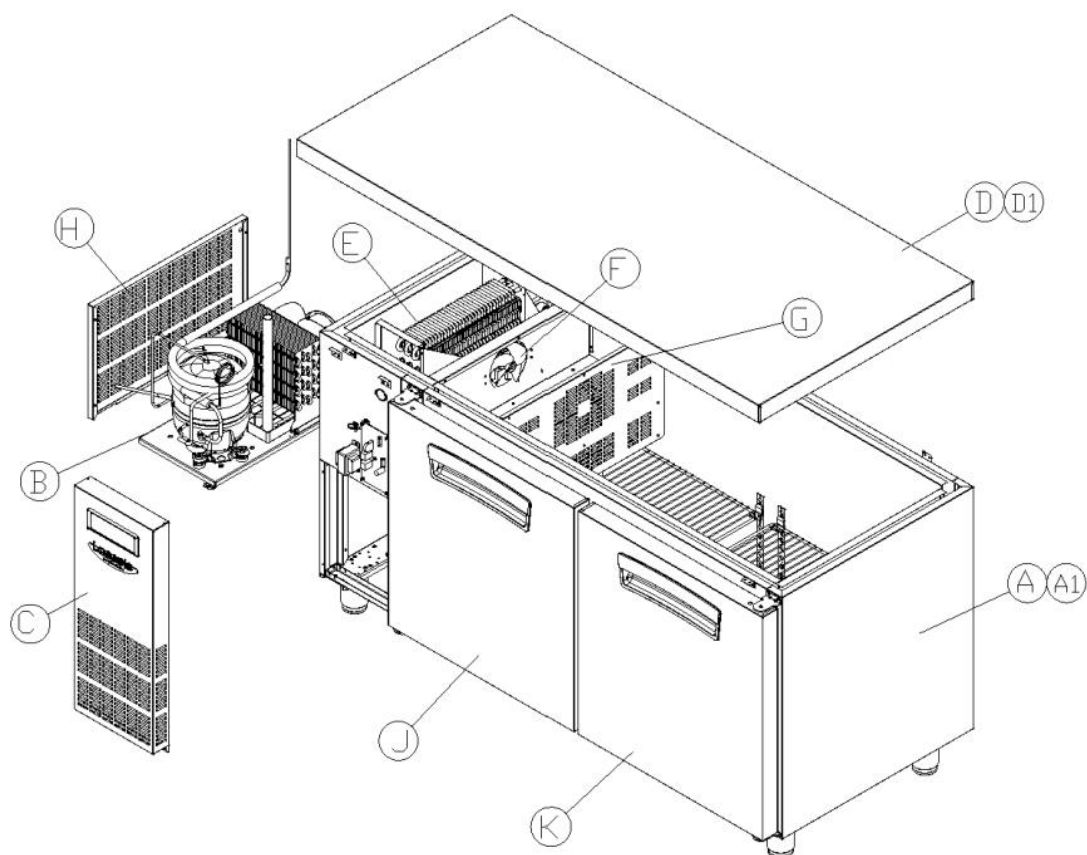

NO	Code No	Description	Qty	Material	Spec
A	R814B-270	ASSY CABI PRE(2B-1500)	1	-	LNRT-2B-1500
A1	R814B-800	ASSY CABI PRE(W1500)_GN	1	-	LERT-2B-1500
B	R815A-520	ASSY UNIT(SK170Q-L1U)	1	-	SK170Q-L1U
C	R858E-290	COVER FRONT AS(TABLE)	1	-	TABLE
D	R875A-460	ASSY TABLE TOP(2B-1500)	1	-	LNRT-2B-1500
D1	R875A-130	ASSY TABLE TOP(2C-1500)	1	-	LNRT-2C-1500
E	R214A-110	EVAPORATOR REF	1	AL	
F	R840A-170	ASSY EVA 1M(D700)	1	-	-
G	R325A-900	COVER EVA D700(1M)	1	STS443CT 2B	T0.5*522*318.2
H	R325B-030	COVER SIDE(D700)	1	STS430 #4	T0.5*603.2*345
J	R817B-870	ASSY DOOR LF(W1500)	1	-	LNRT-2B-1500
K	R817B-900	ASSY DOOR RH(W1500)	1	-	LNRT-2B-1500

d.LNRT-3B/2C-1800, LERT-3B/2C-1800

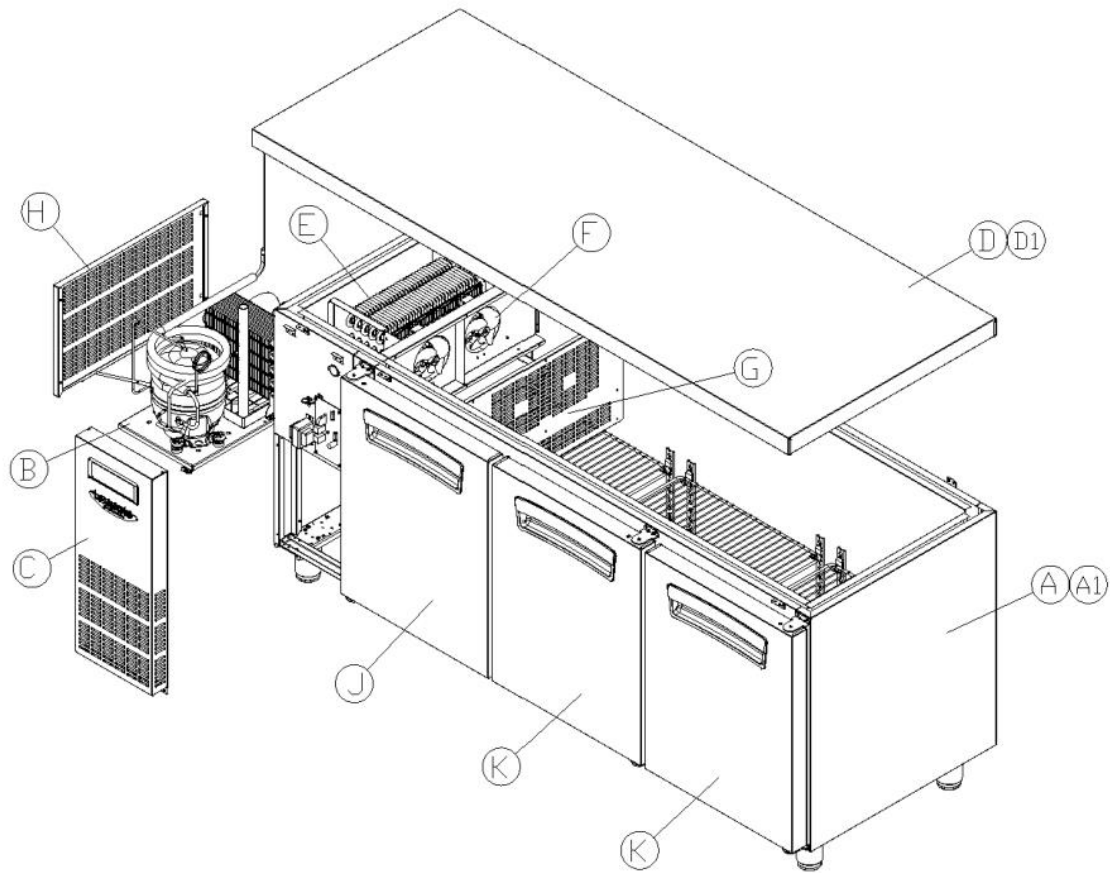

NO	Code No	Description	Qty	Material	Spec
A	R814B-300	ASSY CABI PRE(3B-1800)	1	-	LNRT-3B-1800
A1	R814B-810	ASSY CABI PRE(W1800)_GN	1	-	LERT-3B-1800
B	R815A-540	ASSY UNIT(SK182Q-L2U)	1	-	SK182Q-L2U
C	R858E-290	COVER FRONT AS(TABLE)	1	-	TABLE
D	R875A-470	ASSY TABLE TOP(3B-1800)	1	-	LNRT-3B-1800
D1	R875A-160	ASSY TABLE TOP(3C-1800)	1	-	LNRT-3C-1800
E	R214A-120	EVAPORATOR FEF	1	AL	
F	R840A-200	ASSY EVA 2M(D700)	1	-	-
G	R325A-910	COVER EVA D700(2M)	1	STS443CT 2B	T0.5*522*318.2
H	R325B-030	COVER SIDE(D700)	1	STS430 #4	T0.5*603.2*345
J	R817B-880	ASSY DOOR LF(W1800)	1	-	LNRT-3B-1800
K	R817B-910	ASSY DOOR RH(W1800)	2	-	LNRT-3B-1800

e.LGRT-1B/1C-900/900L, LEGRT-1B/1C-900/900L

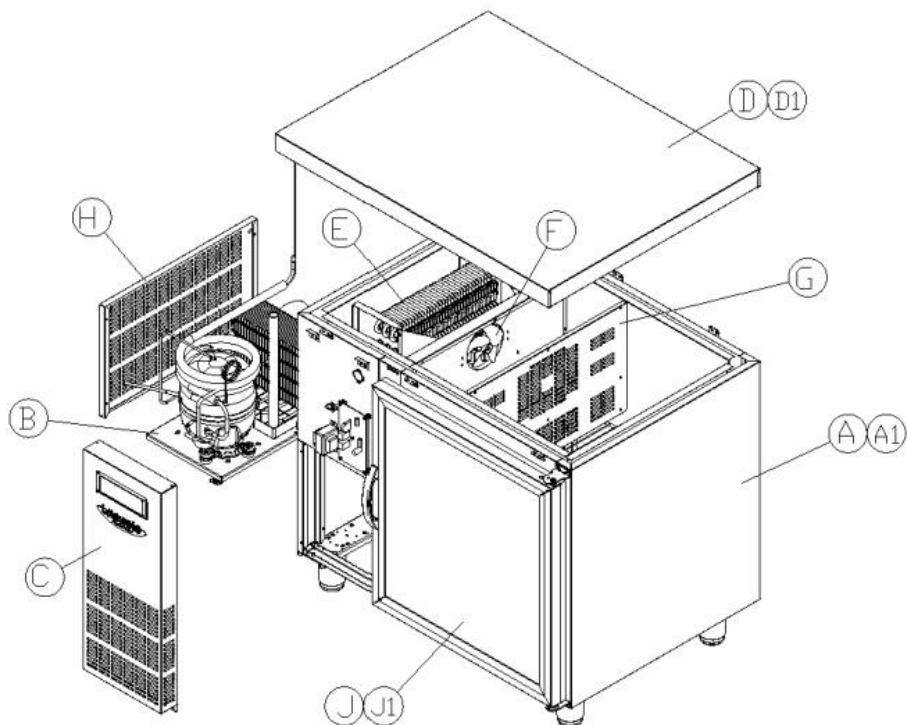

NO	Code No	Description	Qty	Material	Spec
A	R810B-990	ASSY INNER CASE(1B-900)	1	-	LNRT-1B-900
A1	R810C-490	ASSYINNER CASE(W900)_GN	1	-	LERT-1B-900
B	R815A-520	ASSY UNIT(SK170Q-L1U)	1	-	SK170Q-L1U
C	R858E-290	COVER FRONT AS(TABLE)	1	-	TABLE
D	R875A-440	ASSY TABLE TOP(1B-900)	1		LNRT-1B-900
D1	R875A-070	ASSY TABLE TOP(1C-900)	1		LNRT-1C-900
E	R214A-110	EVAPORATOR REF	1	AL	
F	R840A-170	ASSY EVA 1M(D700)	1	-	-
G	R325A-900	COVER EVA D700(1M)	1	STS443CT 2B	T0.5*522*318.2
H	R325B-030	COVER SIDE(D700)	1	STS430 #4	T0.5*603.2*345
J	R817C-230	ASSY GLASS DOOR RH(900)	1		LGRT-1B-900
J1	R817C-240	ASSY GLASS DOOR LF(900)	1		LGRT-1B-900L

f.LGRT-2B/2C-1200, LEGRT-2B/2C-1200

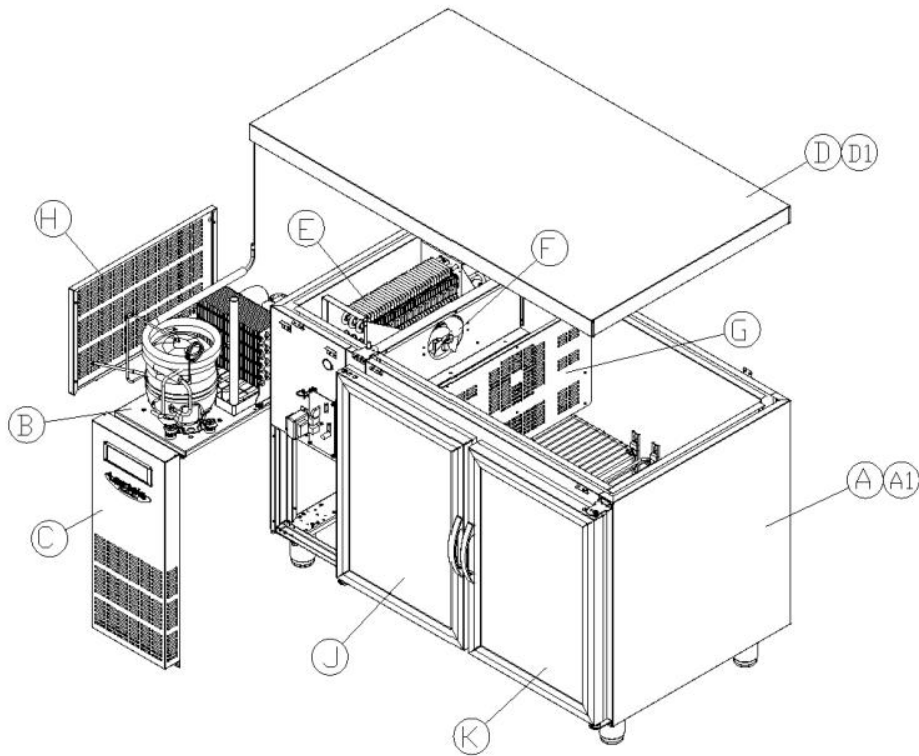

NO	Code No	Description	Qty	Material	Spec
A	R814B-240	ASSY CABI PRE(2B-1200)	1	-	LNRT-2B-1200
A1	R814B-790	ASSY CABI PRE(W1200)_GN	1	-	LERT-2B-1200
B	R815A-520	ASSY UNIT(SK170Q-L1U)	1	-	SK170Q-L1U
C	R858E-290	COVER FRONT AS(TABLE)	1	-	TABLE
D	R875A-450	ASSY TABLE TOP(2B-1200)	1		LNRT-2B-1200
D1	R875A-100	ASSY TABLE TOP(2C-1200)	1		LNRT-2C-1200
E	R214A-110	EVAPORATOR REF	1	AL	
F	R840A-170	ASSY EVA 1M(D700)	1	-	-
G	R325A-900	COVER EVA D700(1M)	1	STS443CT 2B	T0.5*522*318.2
H	R325B-030	COVER SIDE(D700)	1	STS430 #4	T0.5*603.2*345
J	R817C-260	ASSY GLASS DOOR LF(1200)	1		LGRT-2B-1200
K	R817C-250	ASSY GLASS DOOR RH(1200)	1		LGRT-2B-1200

g.LGRT-2B/2C-1500, LEGRT-2B/2C-1500

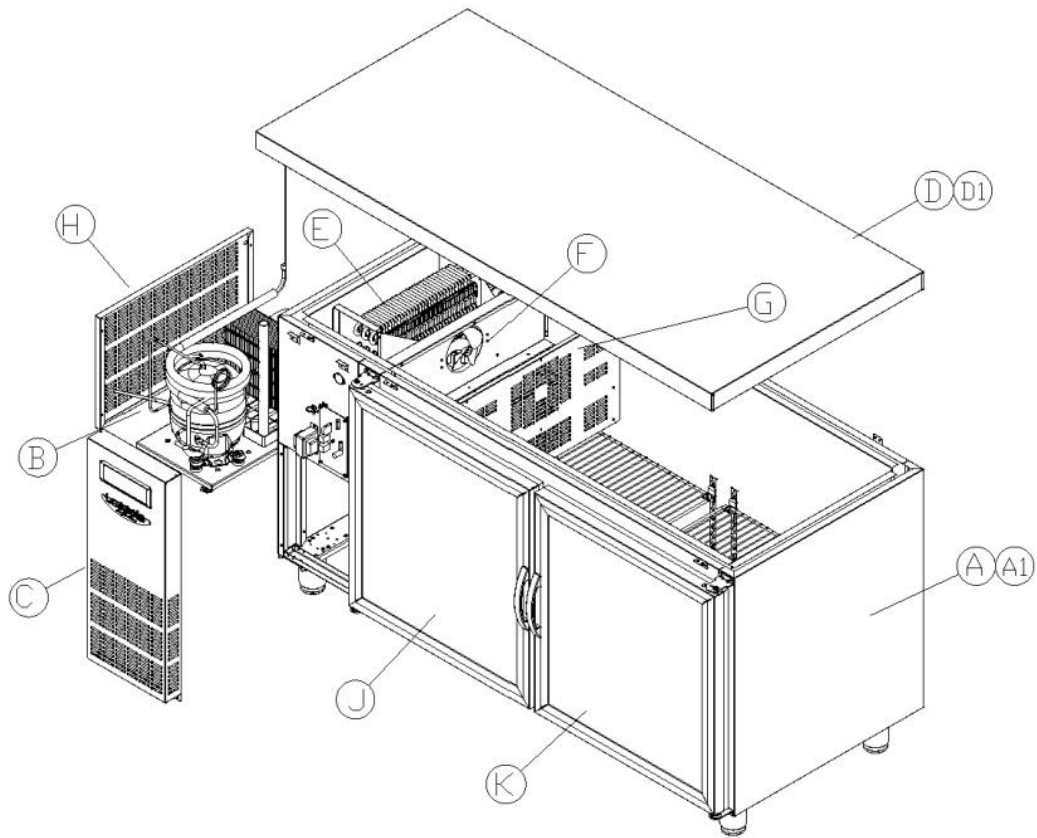

NO	Code No	Description	Qty	Material	Spec
A	R814B-270	ASSY CABI PRE(2B-1500)	1	-	LNRT-2B-1500
A1	R814B-800	ASSY CABI PRE(W1500)_GN	1	-	LERT-2B-1500
B	R815A-520	ASSY UNIT(SK170Q-L1U)	1	-	SK170Q-L1U
C	R858E-290	COVER FRONT AS(TABLE)	1	-	TABLE
D	R875A-460	ASSY TABLE TOP(2B-1500)	1	-	LNRT-2B-1500
D1	R875A-130	ASSY TABLE TOP(2C-1500)	1	-	LNRT-2C-1500
E	R214A-110	EVAPORATOR REF	1	AL	
F	R840A-170	ASSY EVA 1M(D700)	1	-	-
G	R325A-900	COVER EVA D700(1M)	1	STS443CT 2B	T0.5*522*318.2
H	R325B-030	COVER SIDE(D700)	1	STS430 #4	T0.5*603.2*345
J	R817C-280	ASSY GLASS DOOR LF(1500)	1	-	LGRT-2B-1500
K	R817C-270	ASSY GLASS DOOR RH(1500)	1	-	LGRT-2B-1500

h.LGRT-3B/2C-1800, LEGRT-3B/2C-1800

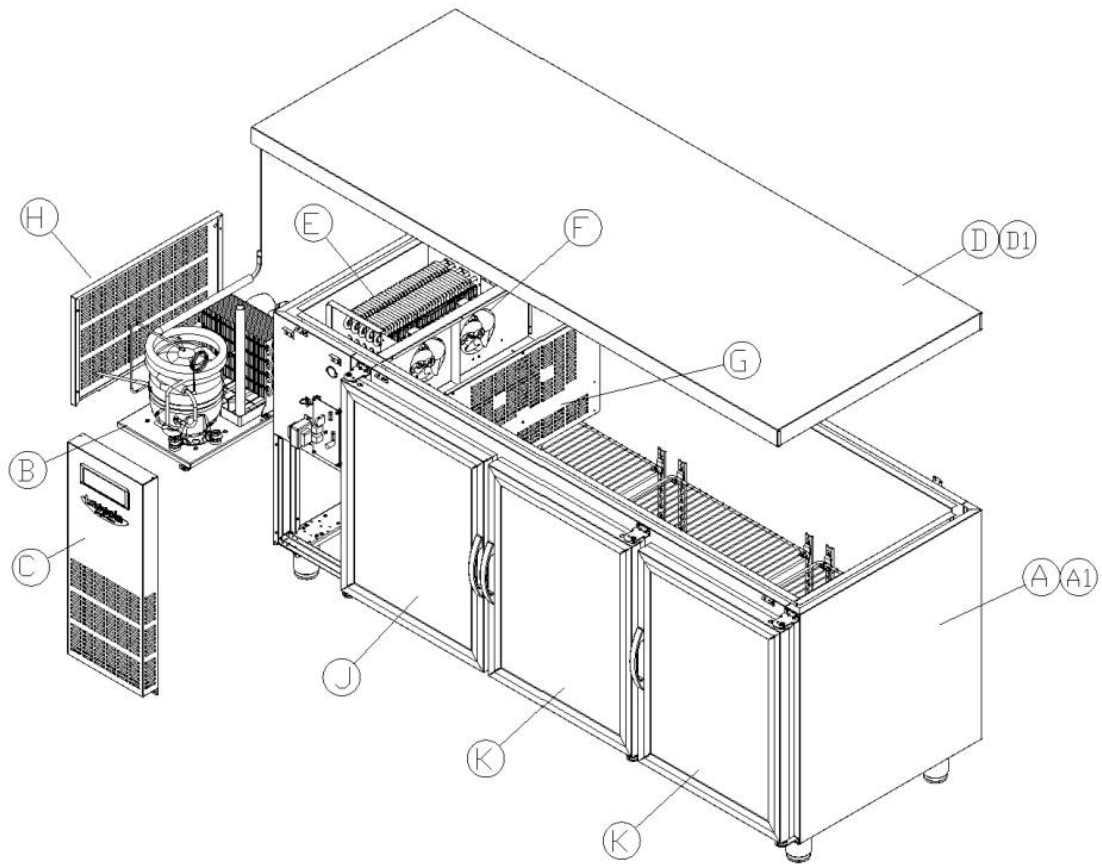

NO	Code No	Description	Qty	Material	Spec
A	R814B-300	ASSY CABI PRE(3B-1800)	1	-	LNRT-3B-1800
A1	R814B-810	ASSY CABI PRE(W1800)_GN	1	-	LERT-3B-1800
B	R815A-540	ASSY UNIT(SK182Q-L2U)	1	-	SK182Q-L2U
C	R858E-290	COVER FRONT AS(TABLE)	1	-	TABLE
D	R875A-470	ASSY TABLE TOP(3B-1800)	1	-	LNRT-3B-1800
D1	R875A-160	ASSY TABLE TOP(3C-1800)	1	-	LNRT-3C-1800
E	R214A-120	EVAPORATOR FEF	1	AL	
F	R840A-200	ASSY EVA 2M(D700)	1	-	-
G	R325A-910	COVER EVA D700(2M)	1	STS443CT 2B	T0.5*522*318.2
H	R325B-030	COVER SIDE(D700)	1	STS430 #4	T0.5*603.2*345
J	R817C-300	ASSY GLASS DOOR LF(1800)	1	-	LGRT-3B-1800
K	R817C-290	ASSY GLASS DOOR RH(1800)	2	-	LGRT-3B-1800

İ.LNFT-1B/1C-900/900L, LEFT-1B/1C-900/900L

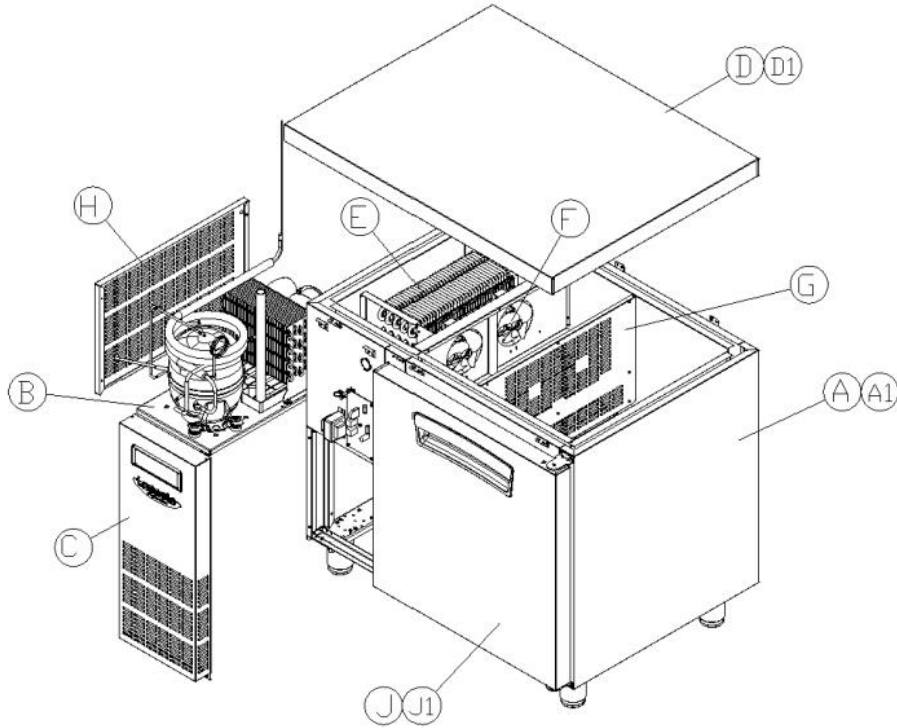

NO	Code No	Description	Qty	Material	Spec
A	R810B-990	ASSY INNER CASE(1B-900)	1	-	LNRT-1B-900
A1	R810C-490	ASSY INNER CASE(W900)_GN	1	-	LERT-1B-900
B	R815A-550	ASSY UNIT(SK1A1Q-L2U)	1	-	SK1A1Q-L2U
C	R858E-290	COVER FRONT AS(TABLE)	1	-	TABLE
D	R875A-440	ASSY TABLE TOP(1B-900)	1		LNRT-1B-900
D1	R875A-070	ASSY TABLE TOP(1C-900)	1		LNRT-1C-900
E	R840A-270	ASSY EVAPORATOR FRE	1	-	EVA + HEATER
F	R840A-200	ASSY EVA 2M(D700)	1	-	
G	R325A-900	COVER EVA D700(1M)	1	STS443CT 2B	T0.5*522*318.2
H	R325B-030	COVER SIDE(D700)	1	STS430 #4	T0.5*603.2*345
J	R817C-170	ASSY DOOR RH(W900)	1		LNRT-1B-900
J1	R817C-160	ASSY DOOR LF(W900)	1		LNRT-1B-900L

j.LNFT-2B/2C-1200, LEFT-2B/2C-1200

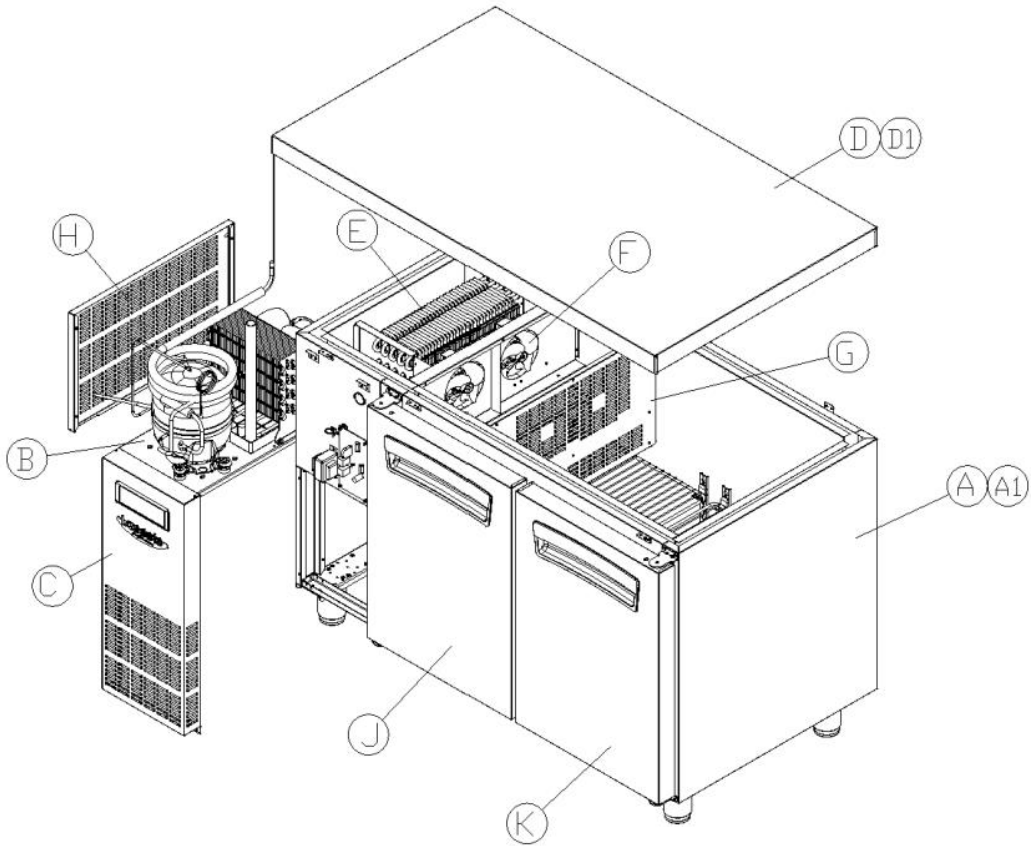

NO	Code No	Description	Qty	Material	Spec
A	R814B-240	ASSY CABI PRE(2B-1200)	1	-	LNRT-2B-1200
A1	R814B-790	ASSY CABI PRE(W1200)_GN	1	-	LERT-2B-1200
B	R815A-640	ASSY UNIT(DK1A3H-L2W)	1	-	DK1A3H-L2W
C	R858E-290	COVER FRONT AS(TABLE)	1	-	TABLE
D	R875A-450	ASSY TABLE TOP(2B-1200)	1		LNRT-2B-1200
D1	R875A-100	ASSY TABLE TOP(2C-1200)	1		LNRT-2C-1200
E	R840A-270	ASSY EVAPORATOR FRE	1	-	EVA + HEATER
F	R840A-200	ASSY EVA 2M(D700)	1	-	
G	R325A-900	COVER EVA D700(1M)	1	STS443CT 2B	T0.5*522*318.2
H	R325B-030	COVER SIDE(D700)	1	STS430 #4	T0.5*603.2*345
J	R817B-860	ASSY DOOR LF(W1200)	1		LNRT-2B-1200
K	R817B-890	ASSY DOOR RH(W1200)	1		LNRT-2B-1200

k.LNFT-2B/2C-1500, LEFT-2B/2C-1500

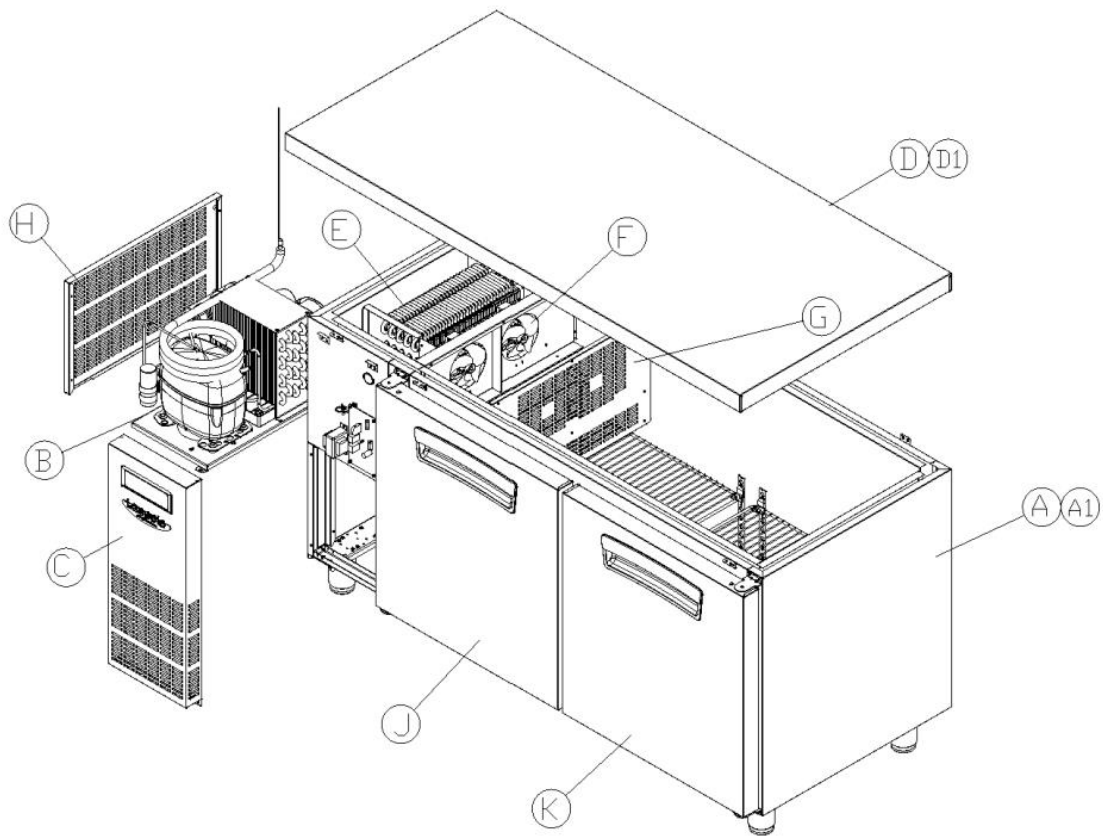

NO	Code No	Description	Qty	Material	Spec
A	R814B-270	ASSY CABI PRE(2B-1500)	1	-	LNRT-2B-1500
A1	R814B-800	ASSY CABI PRE(W1500)_GN	1	-	LERT-2B-1500
B	R815A-650	ASSY UNIT(SC12CLX)	1	-	SC12CLX
C	R858E-290	COVER FRONT AS(TABLE)	1	-	TABLE
D	R875A-460	ASSY TABLE TOP(2B-1500)	1	-	LNRT-2B-1500
D1	R875A-130	ASSY TABLE TOP(2C-1500)	1	-	LNRT-2C-1500
E	R840A-270	ASSY EVAPORATOR FRE	1	-	EVA + HEATER
F	R840A-200	ASSY EVA 2M(D700)	1	-	
G	R325A-900	COVER EVA D700(1M)	1	STS443CT 2B	T0.5*522*318.2
H	R325B-030	COVER SIDE(D700)	1	STS430 #4	T0.5*603.2*345
J	R817B-870	ASSY DOOR LF(W1500)	1	-	LNRT-2B-1500
K	R817B-900	ASSY DOOR RH(W1500)	1	-	LNRT-2B-1500

m.LNFT-3B/3C-1800, LEFT-3B/3C-1800

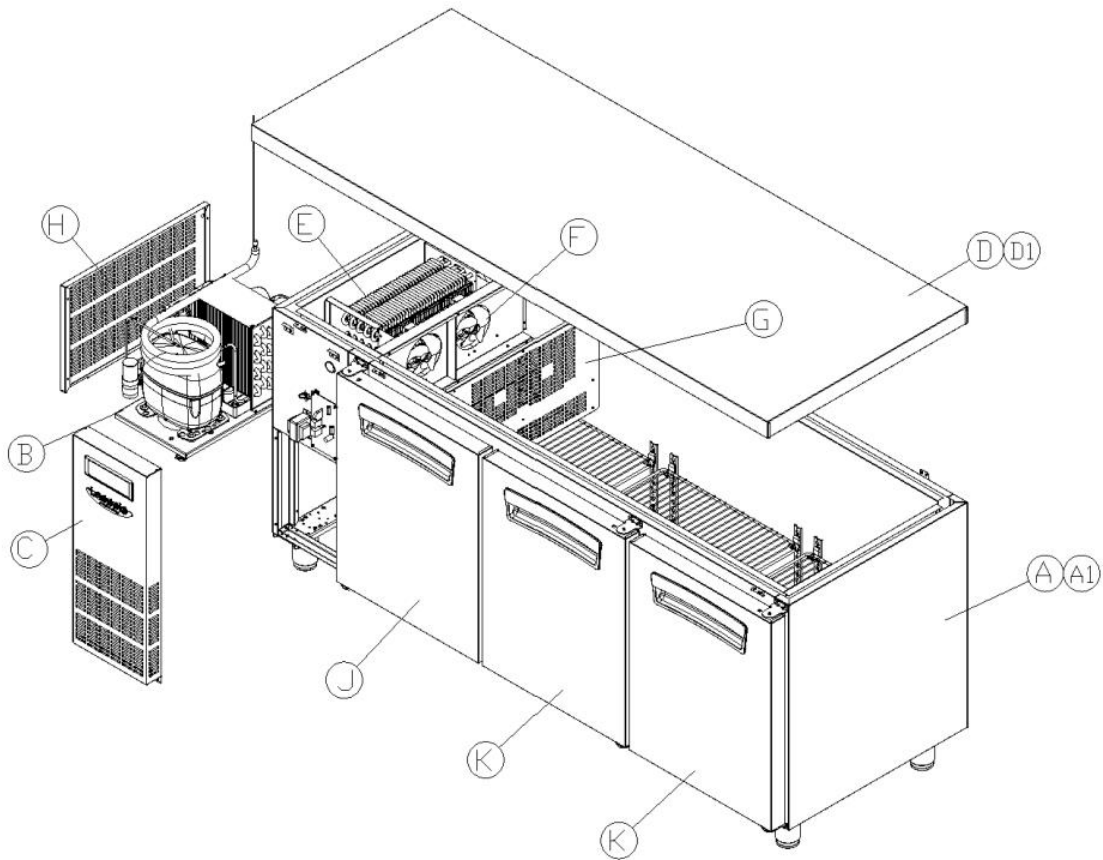

NO	Code No	Description	Qty	Material	Spec
A	R814B-300	ASSY CABI PRE(3B-1800)	1	-	LNRT-3B-1800
A1	R814B-810	ASSY CABI PRE(W1800)_GN	1	-	LERT-3B-1800
B	R815A-650	ASSY UNIT(SC12CLX)	1	-	SC12CLX
C	R858E-290	COVER FRONT AS(TABLE)	1	-	TABLE
D	R875A-470	ASSY TABLE TOP(3B-1800)	1	-	LNRT-3B-1800
D1	R875A-160	ASSY TABLE TOP(3C-1800)	1	-	LNRT-3C-1800
E	R840A-270	ASSY EVAPORATOR FRE	1	-	EVA + HEATER
F	R840A-200	ASSY EVA 2M(D700)	1	-	-
G	R325A-910	COVER EVA D700(2M)	1	STS443CT 2B	T0.5*522*318.2
H	R325B-030	COVER SIDE(D700)	1	STS430 #4	T0.5*603.2*345
J	R817B-880	ASSY DOOR LF(W1800)	1	-	LNRT-3B-1800
K	R817B-910	ASSY DOOR RH(W1800)	2	-	LNRT-3B-1800

n.LNRT-1A-900

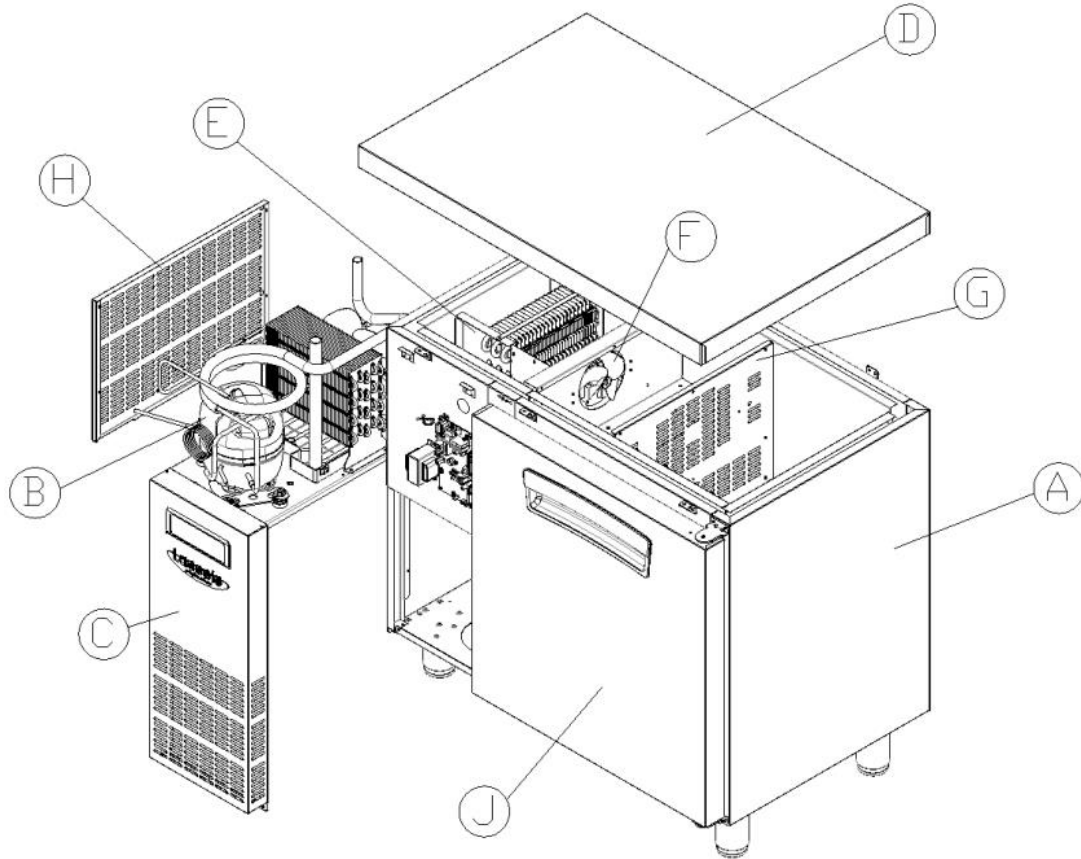

NO	Code No	Description	Qty	Material	Spec
A	R814C-560	ASSY CABI PRE(1A-900)	1	-	LNRT-1A-900
B	R815B-060	ASSY UNIT(MSA170H_D600)	1	-	MSA170H
C	R858E-290	COVER FRONT AS(TABLE)	1	-	TABLE
D	R875A-840	ASSY TABLE TOP(900_D600)	1	STS430 #4	LNRT-1A-900
E	R840A-460	ASSY EVAPORATOR(LNRT_D600)	1	AL	LNRT-1A-900
F	R831A-160	ASSY MOTOR EVA(LNRT_D600)	1	-	-
G	R325C-290	COVER EVA(LNRT_D600)	1	STS443CT	T0.5*444.3*323.6
H	R325C-310	COVER SIDE(D600)	1	STS430 #4	T0.5*342*465.2
J	R817C-170	ASSY DOOR RH(W900)	1		LNRT-1B-900

o.LNRT-2A-1200

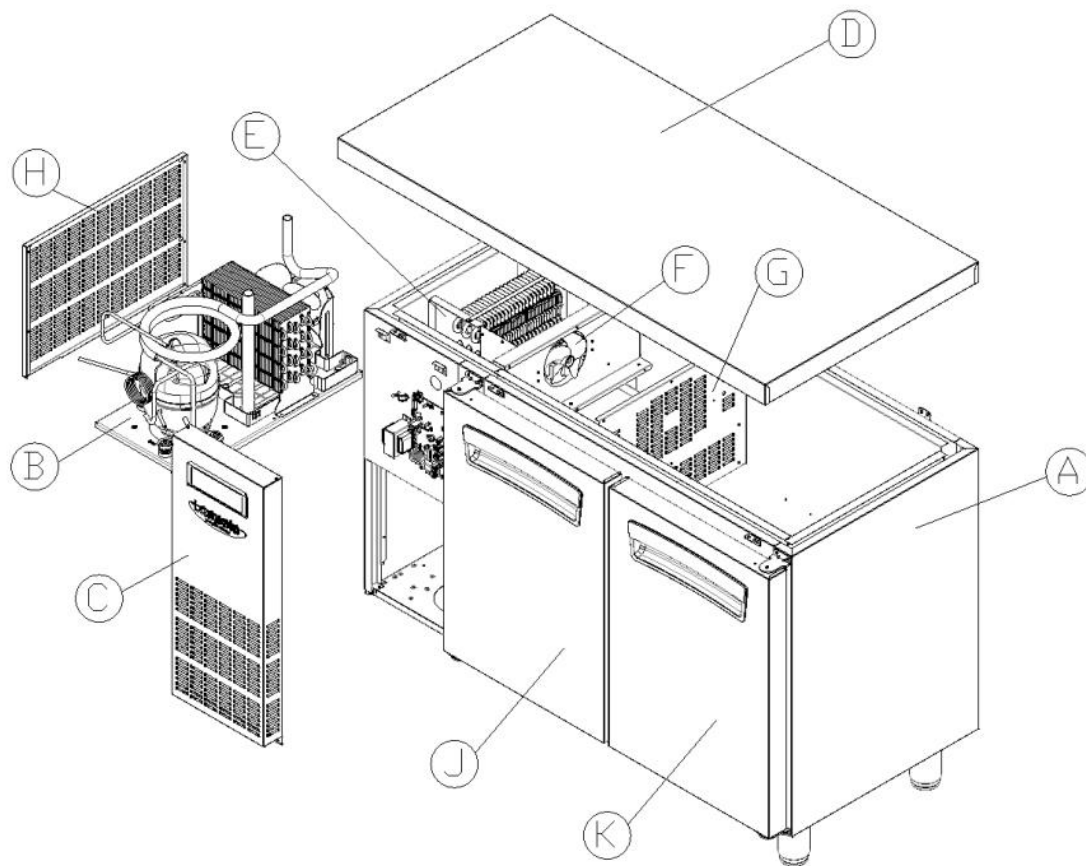

NO	Code No	Description	Qty	Material	Spec
A	R814C-570	ASSY CABI PRE(2A-1200)	1	-	LNRT-2A-1200
B	R815B-060	ASSY UNIT(MSA170H_D600)	1	-	MSA170H
C	R858E-290	COVER FRONT AS(TABLE)	1	-	TABLE
D	R875A-850	ASSY TABLE TOP(1200_D600)	1	STS430 #4	LNRT-2A-1200
E	R840A-460	ASSY EVAPORATOR(LNRT_D600)	1	AL	LNRT-2A-1200
F	R831A-160	ASSY MOTOR EVA(LNRT_D600)	1	-	-
G	R325C-290	COVER EVA(LNRT_D600)	1	STS443CT	T0.5*444.3*323.6
H	R325C-310	COVER SIDE(D600)	1	STS430 #4	T0.5*342*465.2
J	R817B-860	ASSY DOOR LF(W1200)	1		LNRT-2B-1200
K	R817B-890	ASSY DOOR RH(W1200)	1		LNRT-2B-1200

p.LNRT-2A-1500

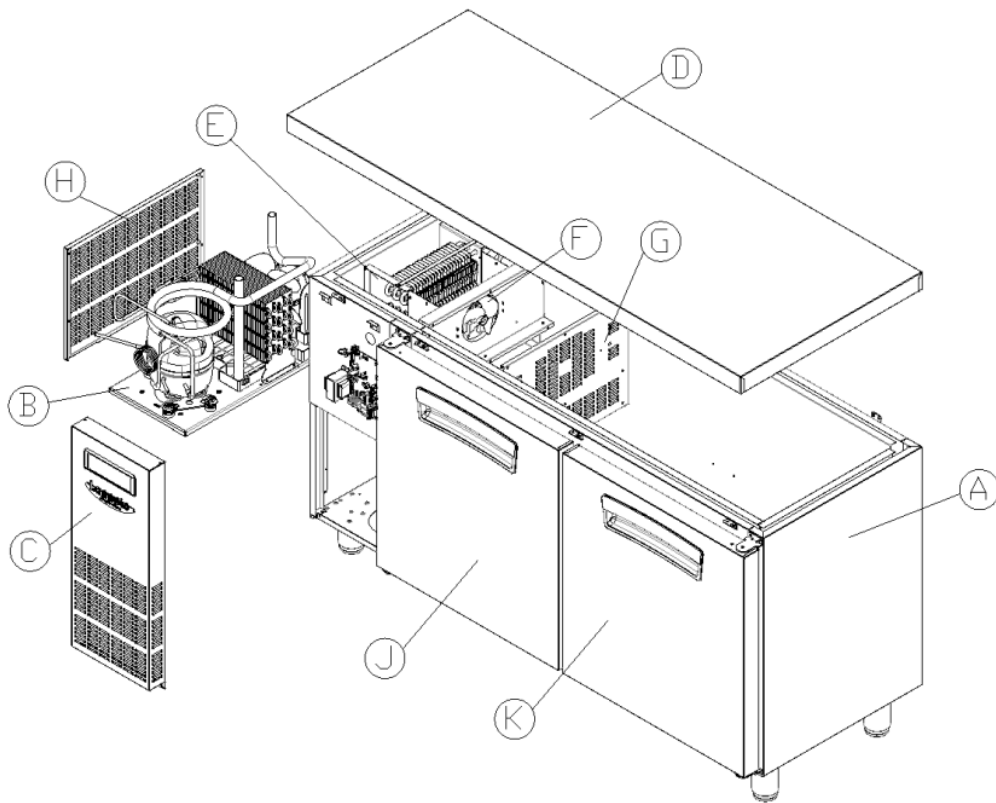

NO	Code No	Description	Qty	Material	Spec
A	R814C-580	ASSY CABI PRE(2A-1500)	1	-	LNRT-2A-1500
B	R815B-060	ASSY UNIT(MSA170H_D600)	1	-	MSA170H
C	R858E-290	COVER FRONT AS(TABLE)	1	-	TABLE
D	R875A-860	ASSY TABLE TOP(1500_D600)	1	-	LNRT-2A-1500
E	R840A-460	ASSY EVAPORATOR(LNRT_D600)	1	AL	LNRT-2A-1500
F	R831A-160	ASSY MOTOR EVA(LNRT_D600)	1	-	-
G	R325C-290	COVER EVA(LNRT_D600)	1	STS443CT	T0.5*444.3*323.6
H	R325C-310	COVER SIDE(D600)	1	STS430 #4	T0.5*342*465.2
J	R817B-870	ASSY DOOR LF(W1500)	1	-	LNRT-2B-1500
K	R817B-900	ASSY DOOR RH(W1500)	1	-	LNRT-2B-1500

q.LNRT-3A-1800

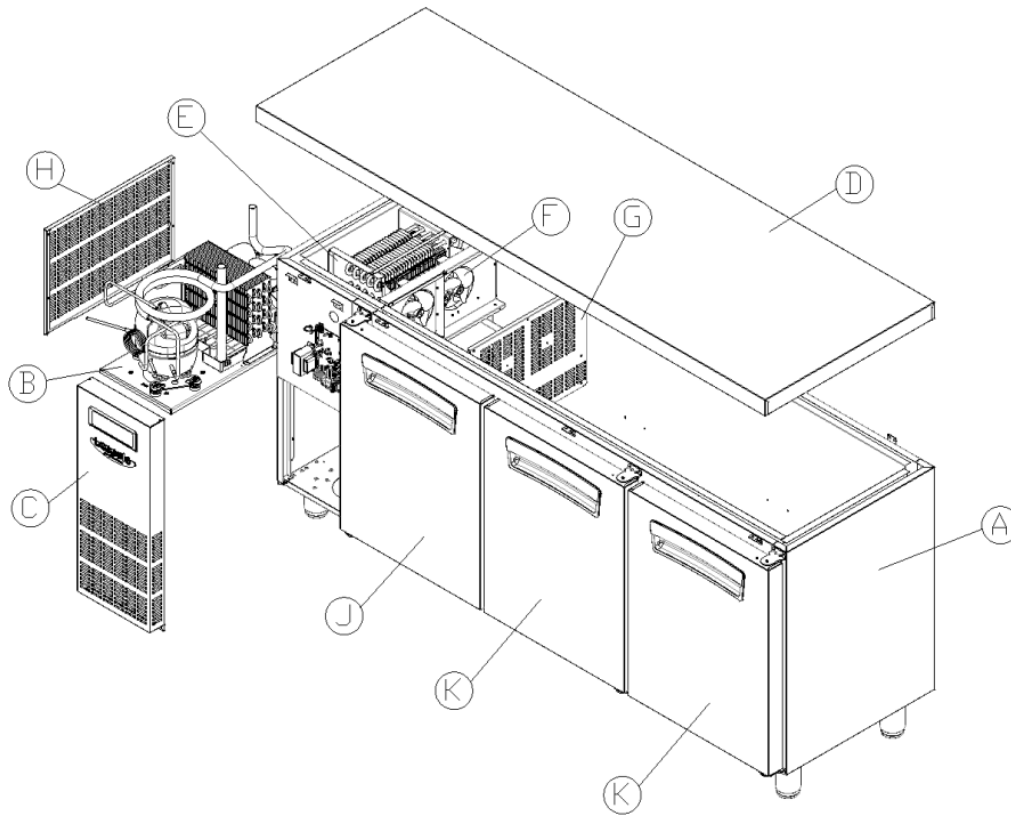

NO	Code No	Description	Qty	Material	Spec
A	R814C-590	ASSY CABI PRE(3A-1800)	1	-	LNRT-3A-1800
B	R815B-070	ASSY UNIT(MSA182H_D600)	1	-	MSA182H
C	R858E-290	COVER FRONT AS(TABLE)	1	-	TABLE
D	R875A-870	ASSY TABLE TOP(1800_D600)	1	-	LNRT-3A-1800
E	R840A-470	ASSY EVAPORATOR (LNRT 1800_D600)	1	AL	LNRT-3A-1800
F	R831A-170	ASSY MOTOR EVA(LNFT_D600)	1	-	-
G	R325C-280	COVER EVA(LNFT_D600)	1	STS443CT 2B	T0.5*444.3*323.6
H	R325C-310	COVER SIDE(D600)	1	STS430 #4	T0.5*603.2*345
J	R817B-880	ASSY DOOR LF(W1800)	1	-	LNRT-3B-1800
K	R817B-910	ASSY DOOR RH(W1800)	2	-	LNRT-3B-1800

r.LNFT-1A-900

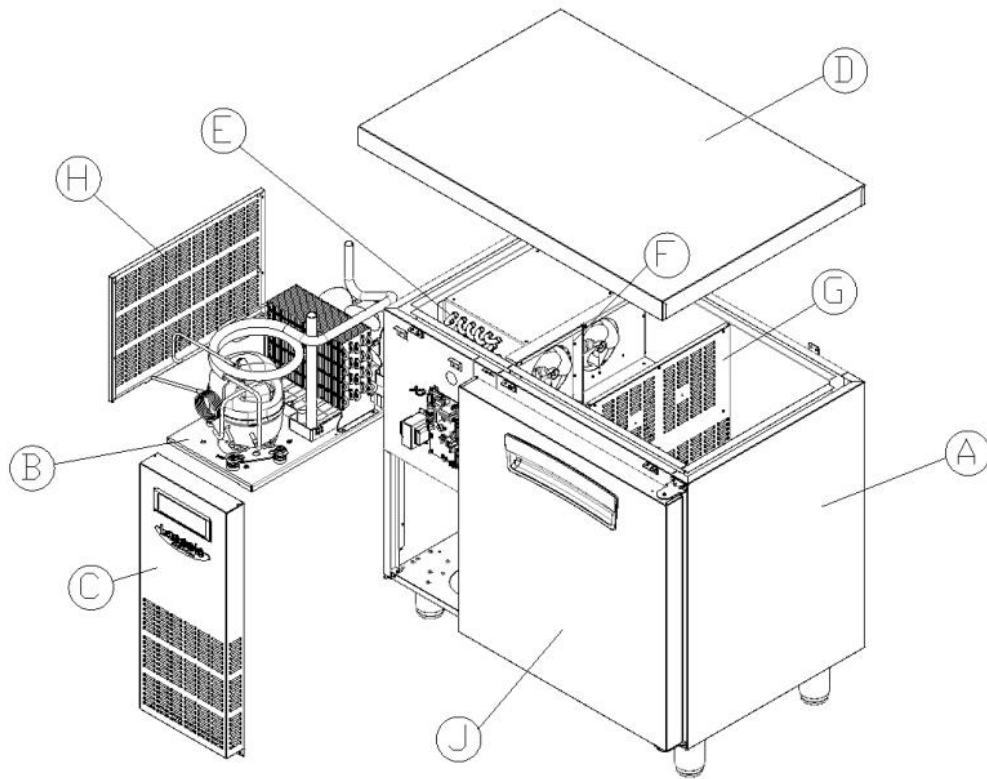

NO	Code No	Description	Qty	Material	Spec
A	R814C-560	ASSY CABI PRE(1A-900)	1	-	LNFT-1A-900
B	R815B-080	ASSY UNIT(MSA190H_D600)	1	-	MSA190H
C	R858E-290	COVER FRONT AS(TABLE)	1	-	TABLE
D	R875A-840	ASSY TABLE TOP(900_D600)	1	STS430 #4	LNFT-1A-900
E	R840A-480	ASSY EVAPORATOR(LNFT_D600)	1	CU	LNFT-1A-900
F	R831A-170	ASSY MOTOR EVA(LNFT_D600)	1	-	-
G	R325C-280	COVER EVA(LNFT_D600)	1	STS443CT	T0.5*444.3*323.6
H	R325C-310	COVER SIDE(D600)	1	STS430 #4	T0.5*342*465.2
J	R817C-170	ASSY DOOR RH(W900)	1		LNRT-1B-900

s.LNFT-2A-1200

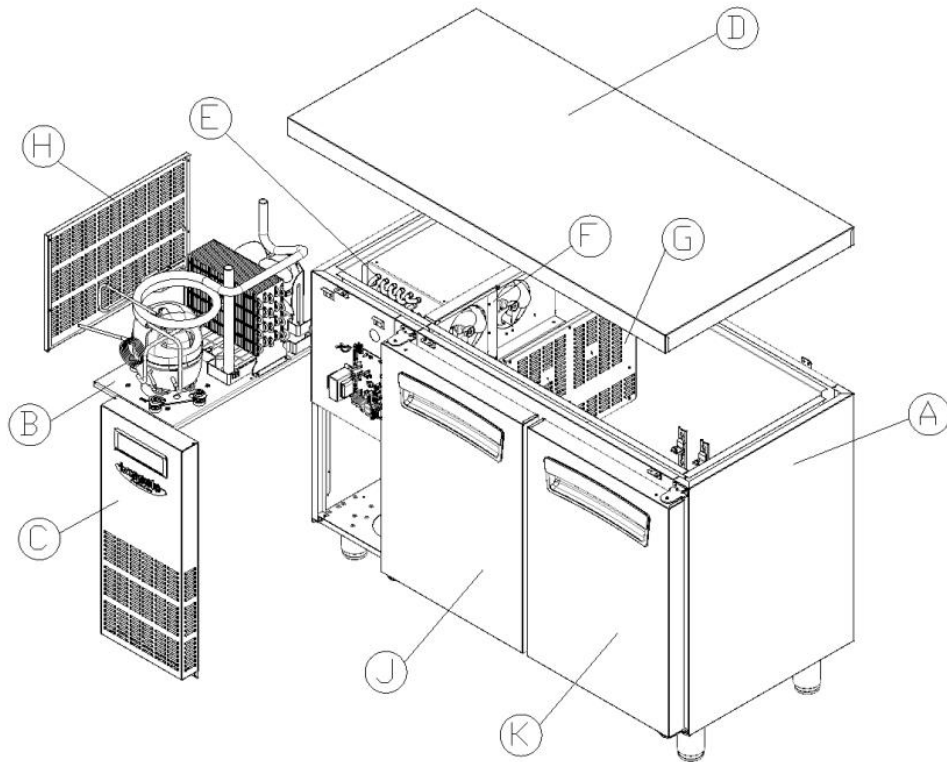

NO	Code No	Description	Qty	Material	Spec
A	R814C-570	ASSY CABI PRE(2A-1200)	1	-	LNFT-2A-1200
B	R815B-320	ASSY UNIT(NF21K5131FU_D600)	1	-	NF21K5131FU
C	R858E-290	COVER FRONT AS(TABLE)	1	-	TABLE
D	R875A-850	ASSY TABLE TOP(1200_D600)	1	STS430 #4	LNFT-2A-1200
E	R840A-480	ASSY EVAPORATOR(LNFT_D600)	1	CU	LNFT-1A-900
F	R831A-170	ASSY MOTOR EVA(LNFT_D600)	1	-	-
G	R325C-280	COVER EVA(LNFT_D600)	1	STS443CT	T0.5*444.3*323.6
H	R325C-310	COVER SIDE(D600)	1	STS430 #4	T0.5*342*465.2
J	R817B-860	ASSY DOOR LF(W1200)	1		LNRT-2B-1200
K	R817B-890	ASSY DOOR RH(W1200)	1		LNRT-2B-1200

t.LNFT-2A-1500

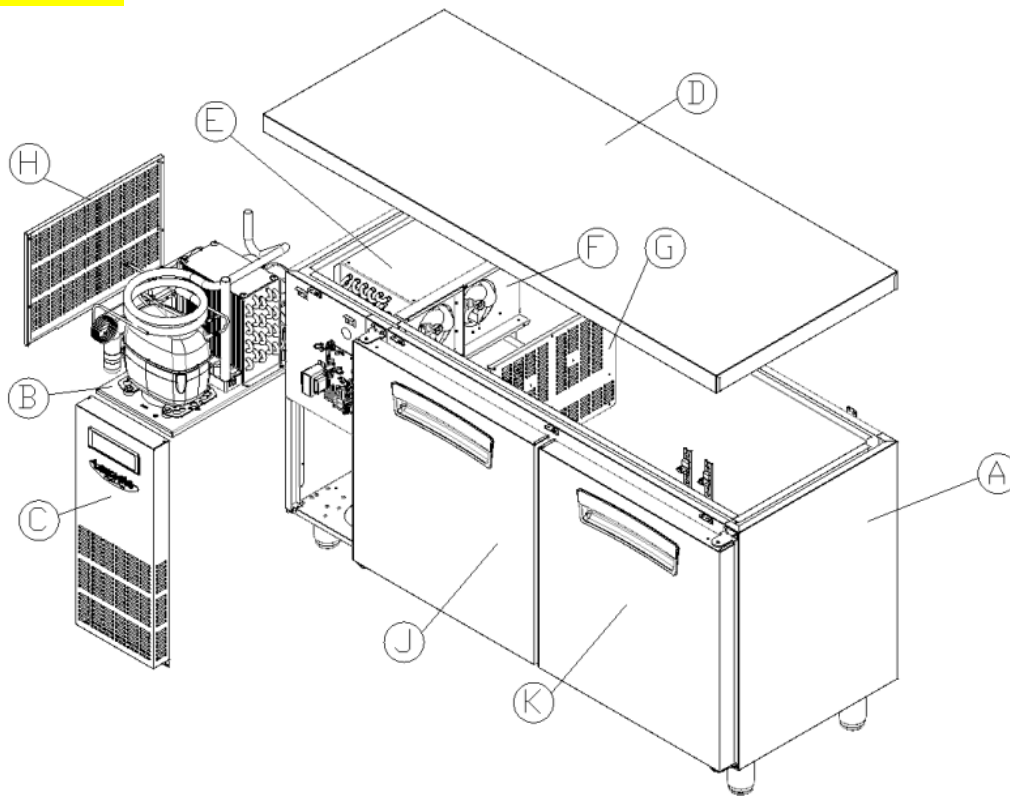

NO	Code No	Description	Qty	Material	Spec
A	R814C-580	ASSY CABI PRE(2A-1500)	1	-	LNFT-2A-1500
B	R815B-090	ASSY UNIT(SC12CLX_D600)	1	-	SC12CLX
C	R858E-290	COVER FRONT AS(TABLE)	1	-	TABLE
D	R875A-860	ASSY TABLE TOP(1500_D600)	1	-	LNFT-2A-1500
E	R840A-480	ASSY EVAPORATOR(LNFT_D600)	1	CU	LNFT-2A-1500
F	R831A-170	ASSY MOTOR EVA(LNFT_D600)	1	-	-
G	R325C-280	COVER EVA(LNFT_D600)	1	STS443CT	T0.5*444.3*323.6
H	R325C-310	COVER SIDE(D600)	1	STS430 #4	T0.5*342*465.2
J	R817B-870	ASSY DOOR LF(W1500)	1	-	LNRT-2B-1500
K	R817B-900	ASSY DOOR RH(W1500)	1	-	LNRT-2B-1500

u.LNFT-3A-1800

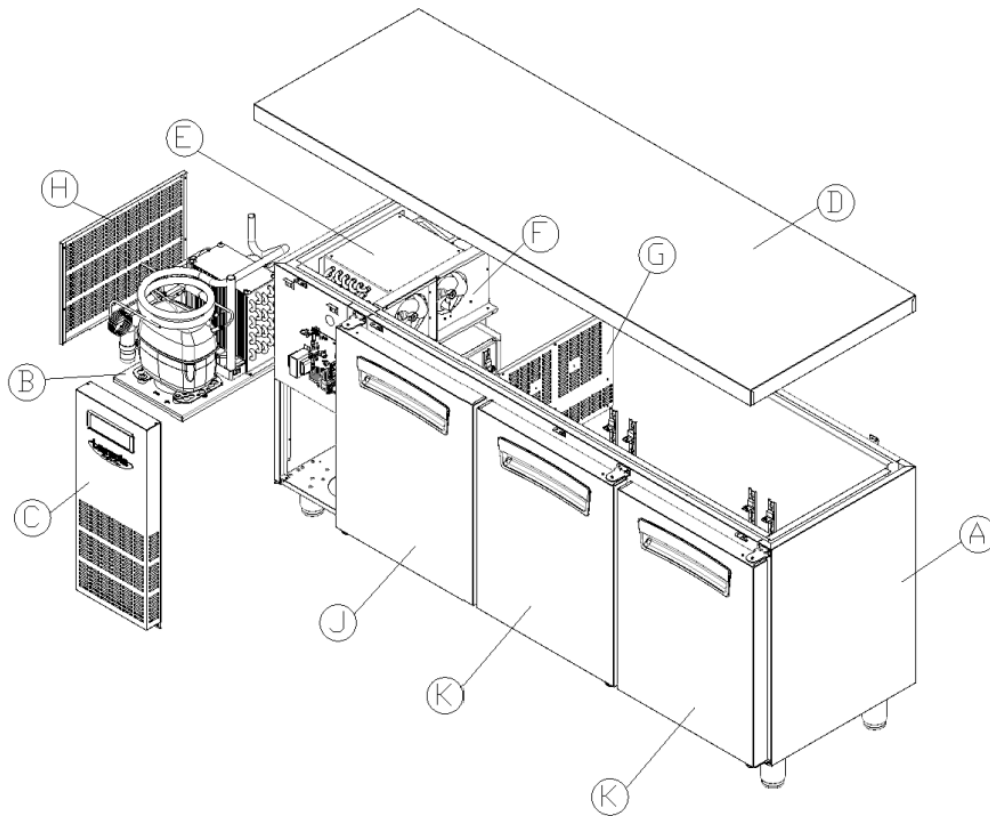

NO	Code No	Description	Qty	Material	Spec
A	R814C-590	ASSY CABI PRE(3A-1800)	1	-	LNFT-3A-1800
B	R815B-090	ASSY UNIT(SC12CLX_D600)	1	-	SC12CLX
C	R858E-290	COVER FRONT AS(TABLE)	1	-	TABLE
D	R875A-870	ASSY TABLE TOP(1800_D600)	1	-	LNFT-3A-1800
E	R840A-480	ASSY EVAPORATOR(LNFT_D600)	1	AL	LNFT-3A-1800
F	R831A-170	ASSY MOTOR EVA(LNFT_D600)	1	-	-
G	R325C-280	COVER EVA(LNFT_D600)	1	STS443CT 2B	T0.5*444.3*323.6
H	R325C-310	COVER SIDE(D600)	1	STS430 #4	T0.5*342*465.2
J	R817B-880	ASSY DOOR LF(W1800)	1	-	LNRT-3B-1800
K	R817B-910	ASSY DOOR RH(W1800)	2	-	LNRT-3B-1800

B. Assembly Unit

a.R815A-520ASSY UNIT(SK170Q-L1U)

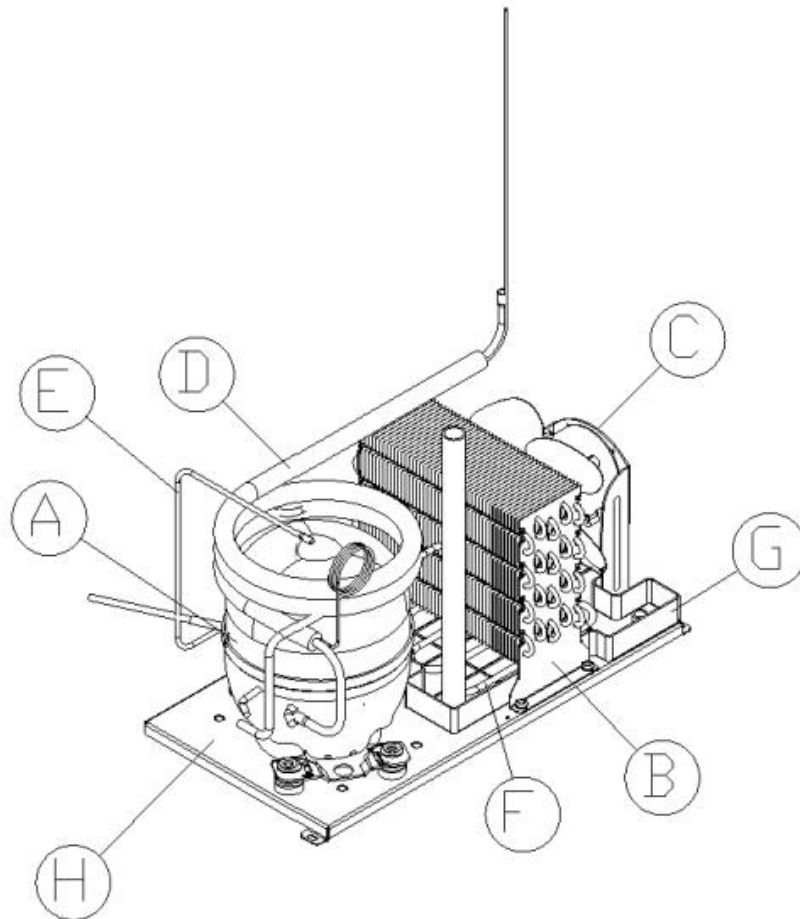

NO	Code No	Description	Qty	Material	Spec
A	R714A-290	COMPRESSOR (SK170H-L2WA)	1	-	SAMSUNG R-134A, 220V/50HZ
B	R212A-070	CONDENSER WIRE(8)	1	Steel Pipe	OD4.76*0.7t
C	R8323-280	ASSY CONDENSER FAN MOTOR	1	-	9W CCW ASSY
D	R319B-900	PIPE SUCTION(LNRT)	1	CU PIPE	OD7.94+Capi
E	R319B-520	PIPE COND OUT(NRT TABLE)	1	CU PIPE	OD4.76
F	R319B-670	PIPE CASE DRAIN(SIDE TABLE)	1	CU PIPE	OD6.35
G	R321A-810	CASE DRAIN	1	ABS	T1.5
H	R359D-960	PLATE UNIT BASE(TABLE)	1	GI	T1.2

b.R815A-540 ASSY UNIT(SK182Q-L2U)

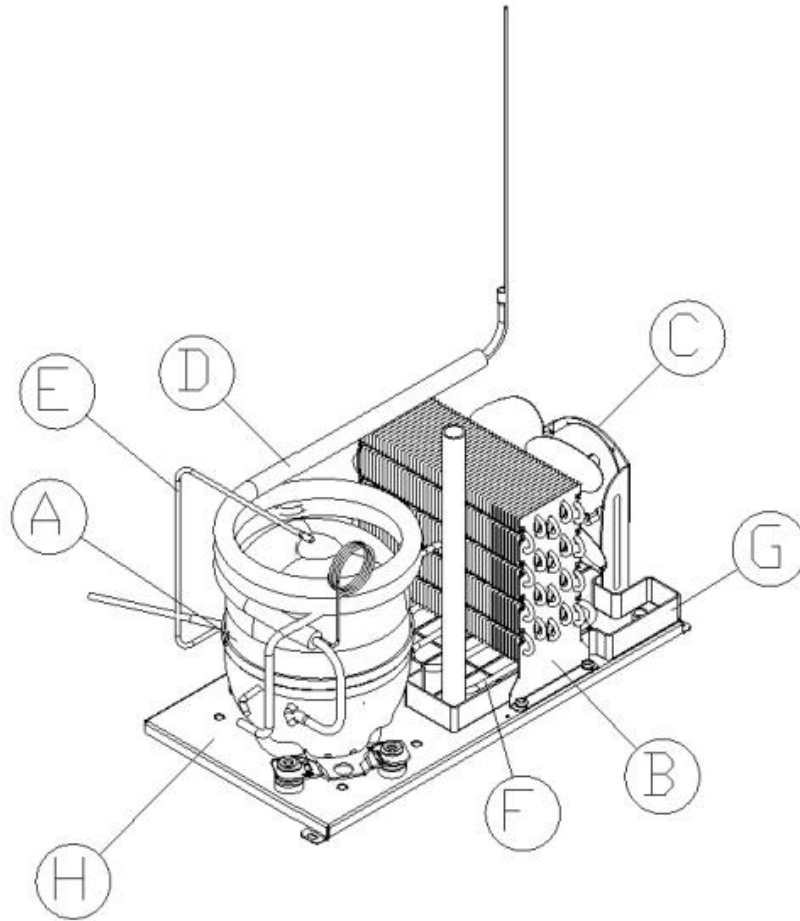

NO	Code No	Description	Qty	Material	Spec
A	R714A-340	COMPRESSOR (SK182H-L2UA)	1	-	SAMSUNG R-134A, 220V/50HZ
B	R212A-070	CONDENSER WIRE(8)	1	Steel Pipe	OD4.76*0.7t
C	R8323-280	ASSY CONDENSER FAN MOTOR	1	-	9W CCW ASSY
D	R319B-900	PIPE SUCTION(LNRT)	1	CU PIPE	OD7.94+Capi
E	R319B-520	PIPE COND OUT(NRT TABLE)	1	CU PIPE	OD4.76
F	R319B-670	PIPE CASE DRAIN(SIDE TABLE)	1	CU PIPE	OD6.35
G	R321A-810	CASE DRAIN	1	ABS	T1.5
H	R359D-960	PLATE UNIT BASE(TABLE)	1	GI	T1.2

C. R815A-550ASSY UNIT(SK1A1Q-L2U)

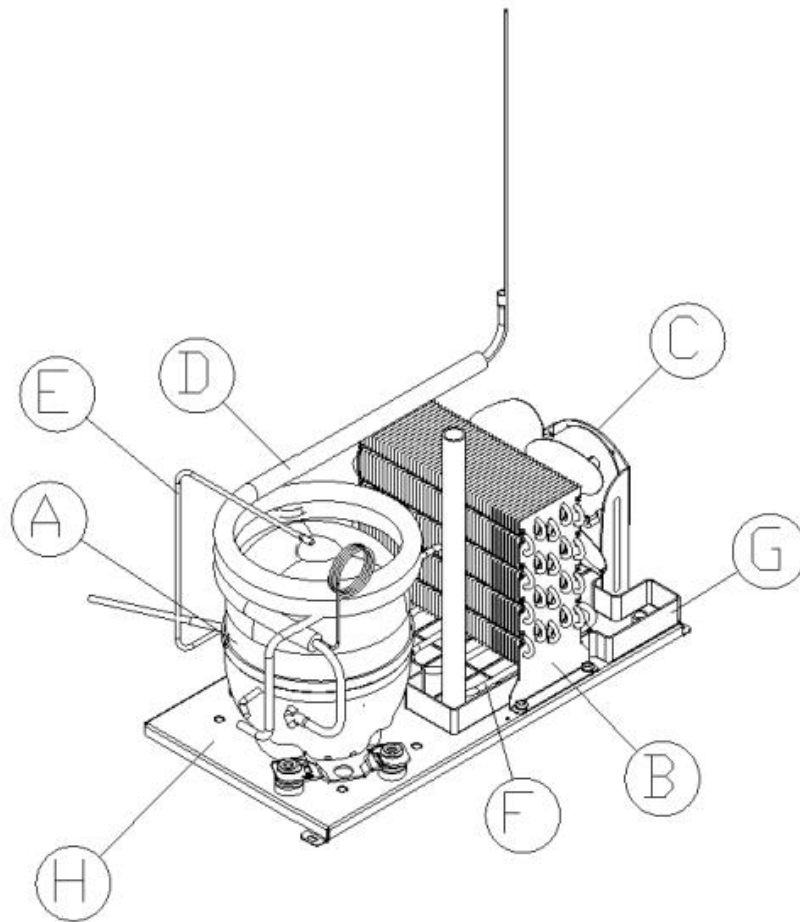

NO	Code No	Description	Qty	Material	Spec
A	R7439-170	COMPRESSOR (SK1A1Q-L2U)	1	-	SAMSUNG R-134A, 220V/50HZ
B	R212A-070	CONDENSER WIRE(8)	1	Steel Pipe	OD4.76*0.7t
C	R8323-280	ASSY CONDENSER FAN MOTOR	1	-	9W CCW ASSY
D	R319B-910	PIPE SUCTION(LNFT)	1	CU PIPE	OD7.94+Capi
E	R319B-520	PIPE COND OUT(NRT TABLE)	1	CU PIPE	OD4.76
F	R319B-670	PIPE CASE DRAIN(SIDE TABLE)	1	CU PIPE	OD6.35
G	R321A-810	CASE DRAIN	1	ABS	T1.5
H	R359D-960	PLATE UNIT BASE(TABLE)	1	GI	T1.2

d. R815A-640ASSY UNIT(DK1A3H-L2W)

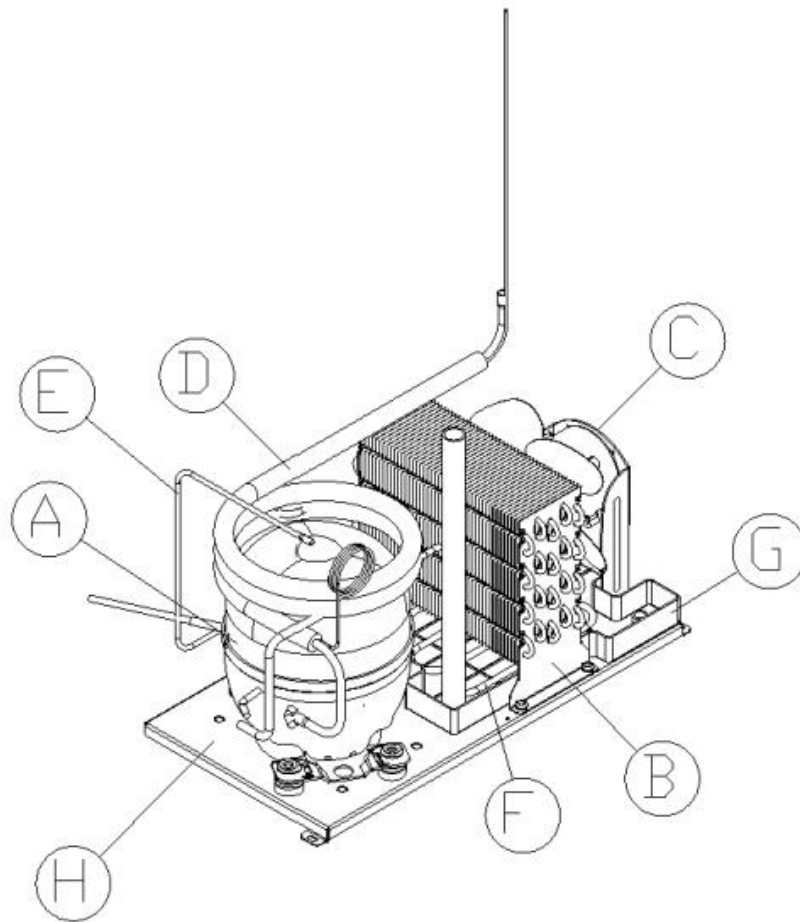

NO	Code No	Description	Qty	Material	Spec
A	R7439-620	COMPRESSOR(DK1A3H-L2W)	1	-	SAMSUNG R-134A, 220V/50HZ
B	R212A-070	CONDENSER WIRE(8)	1	Steel Pipe	OD4.76*0.7t
C	R8323-280	ASSY CONDENSER FAN MOTOR	1	-	9W CCW ASSY
D	R319B-910	PIPE SUCTION(LNFT)	1	CU PIPE	OD7.94+Capi
E	R319B-520	PIPE COND OUT(NRT TABLE)	1	CU PIPE	OD4.76
F	R319B-670	PIPE CASE DRAIN(SIDE TABLE)	1	CU PIPE	OD6.35
G	R321A-810	CASE DRAIN	1	ABS	T1.5
H	R359D-960	PLATE UNIT BASE(TABLE)	1	GI	T1.2

e. R815A-650ASSY UNIT(SC12CLX_D700)

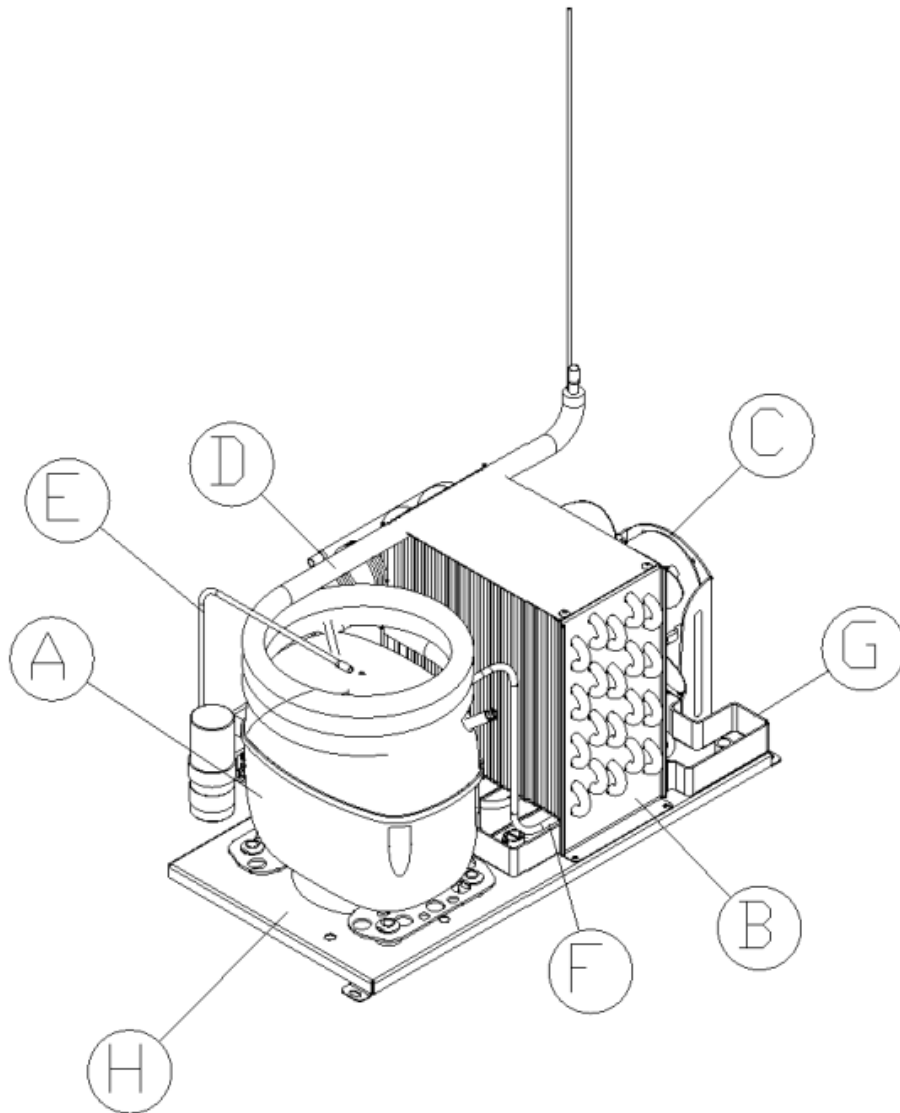

NO	Code No	Description	Qty	Material	Spec
A	R714A-030	COMPRESSOR(SC12CLX)	1	-	Danfoss R-404a, 220V/50HZ
B	R212A-070	CONDENSER WIRE(8)	1	Steel Pipe	OD4.76*0.7t
C	R8323-280	ASSY CONDENSER FAN MOTOR	1	-	9W CCW ASSY
D	R319B-910	PIPE SUCTION(LNFT)	1	CU PIPE	OD7.94+Capi
E	R319B-520	PIPE COND OUT(NRT TABLE)	1	CU PIPE	OD4.76
F	R319B-670	PIPE CASE DRAIN(SIDE TABLE)	1	CU PIPE	OD6.35
G	R321A-810	CASE DRAIN	1	ABS	T1.5
H	R359D-960	PLATE UNIT BASE(TABLE)	1	GI	T1.2

f.R815B-060 ASSY UNIT(MSA170H-L1G)

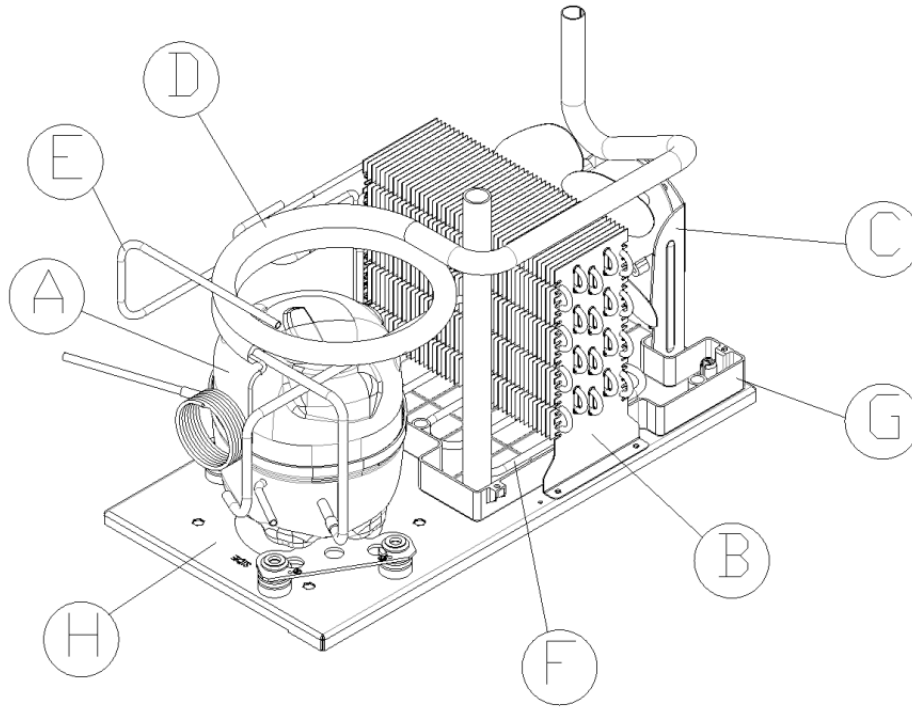

NO	Code No	Description	Qty	Material	Spec
A	R714A-460	COMPRESSOR(MSA170H-L1G)	1	-	SAMSUNG R-134A, 220V, 50/60HZ
B	R212A-070	CONDENSER WIRE(8)	1	Steel Pipe	OD4.76*0.7t
C	R831A-120	ASSY MOTOR CONDENSER	1	-	9W CW ASSY
D	R319C-350	PIPE SUCTION(LNRT)	1	CU PIPE	OD7.94+Capi
E	R319C-020	PIPE COND OUT(SIDE TABLE)	1	CU PIPE	OD6.35*450
F	R319B-670	PIPE CASE DRAIN(SIDE TABLE)	1	CU PIPE	OD6.35
G	R321A-811	CASE DRAIN	1	ABS	T1.5
H	R359I-190	PLATE UNIT BASE-SIDE S	1	GI	T1.6*540.4*286.9

g.R815B-070ASSY UNIT(MSA182H-L2G)

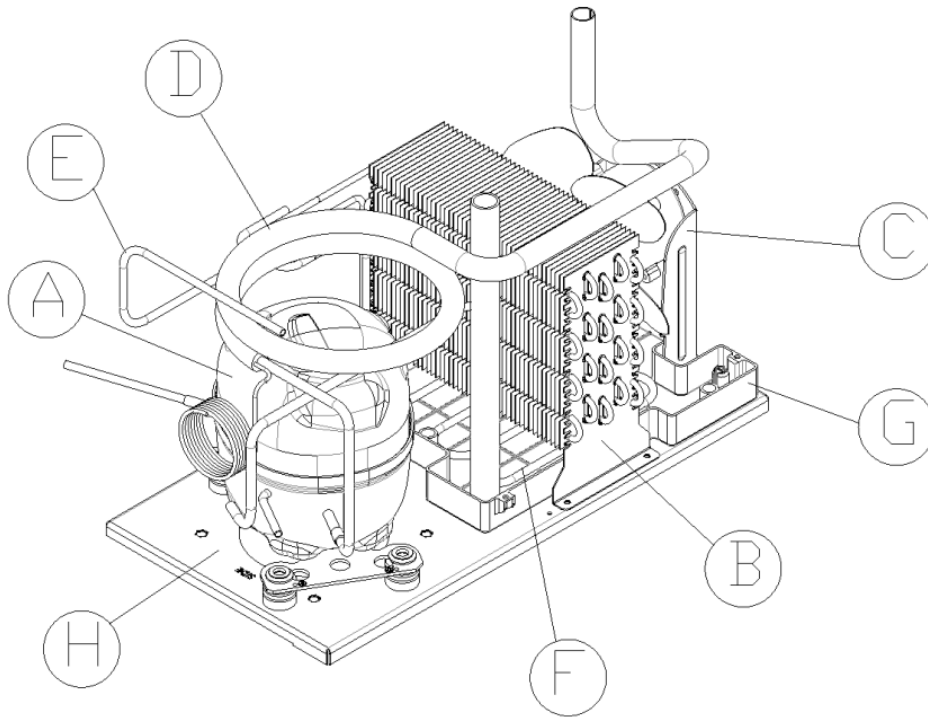

NO	Code No	Description	Qty	Material	Spec
A	R714A-510	COMPRESSOR (MSA182H-L2G)	1	-	SAMSUNG R-134A, 220V, 50/60HZ
B	R212A-070	CONDENSER WIRE(8)	1	Steel Pipe	OD4.76*0.7t
C	R831A-120	ASSY MOTOR CONDENSER	1	-	9W CW ASSY
D	R319C-350	PIPE SUCTION(LNRT)	1	CU PIPE	OD7.94+Capi
E	R319C-020	PIPE COND OUT(SIDE TABLE)	1	CU PIPE	OD4.76
F	R319B-670	PIPE CASE DRAIN(SIDE TABLE)	1	CU PIPE	OD6.35
G	R321A-811	CASE DRAIN	1	ABS	T1.5
H	R359I-190	PLATE UNIT BASE-SIDE S	1	GI	T1.6*540.4*286.9

h.R815B-080ASSY UNIT(MSA190H-L2H)

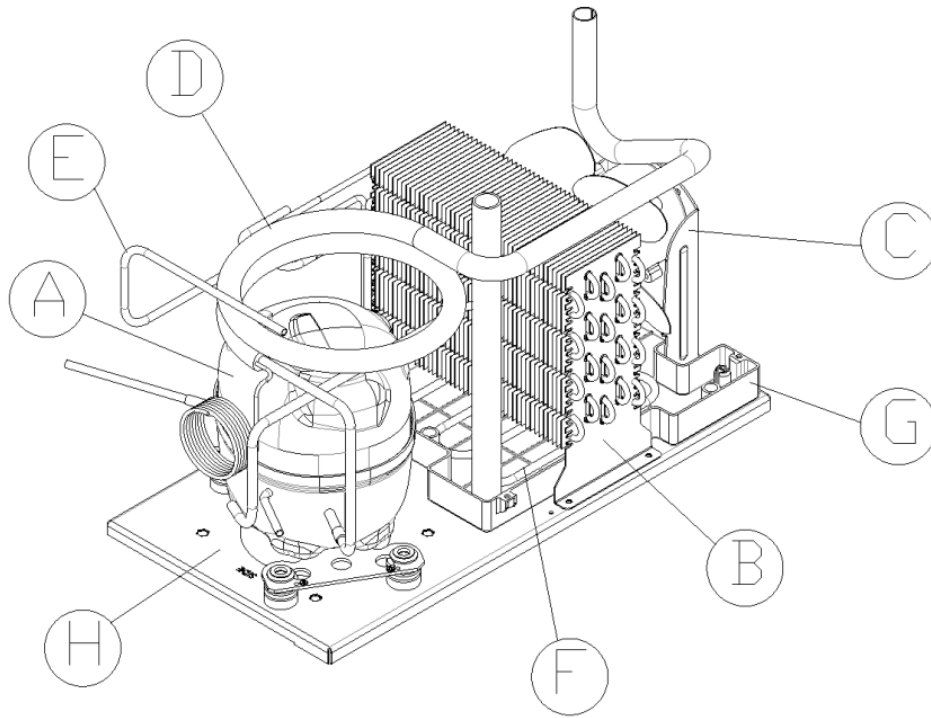

NO	Code No	Description	Qty	Material	Spec
A	R714A-470	COMPRESSOR (MSA190H-L2G)	1	-	SAMSUNG R-134A, 220V, 50/60HZ
B	R212A-070	CONDENSER WIRE(8)	1	Steel Pipe	OD4.76*0.7t
C	R831A-120	ASSY MOTOR CONDENSER	1	-	9W CW ASSY
D	R319C-360	PIPE SUCTION(LNFT)	1	CU PIPE	OD7.94+Capi
E	R319C-020	PIPE COND OUT(SIDE TABLE)	1	CU PIPE	OD4.76
F	R319B-670	PIPE CASE DRAIN(SIDE TABLE)	1	CU PIPE	OD6.35
G	R321A-811	CASE DRAIN	1	ABS	T1.5
H	R359I-190	PLATE UNIT BASE-SIDE S	1	GI	T1.6*540.4*286.9

i.R815B-320ASSY UNIT(NF21K5131FU)

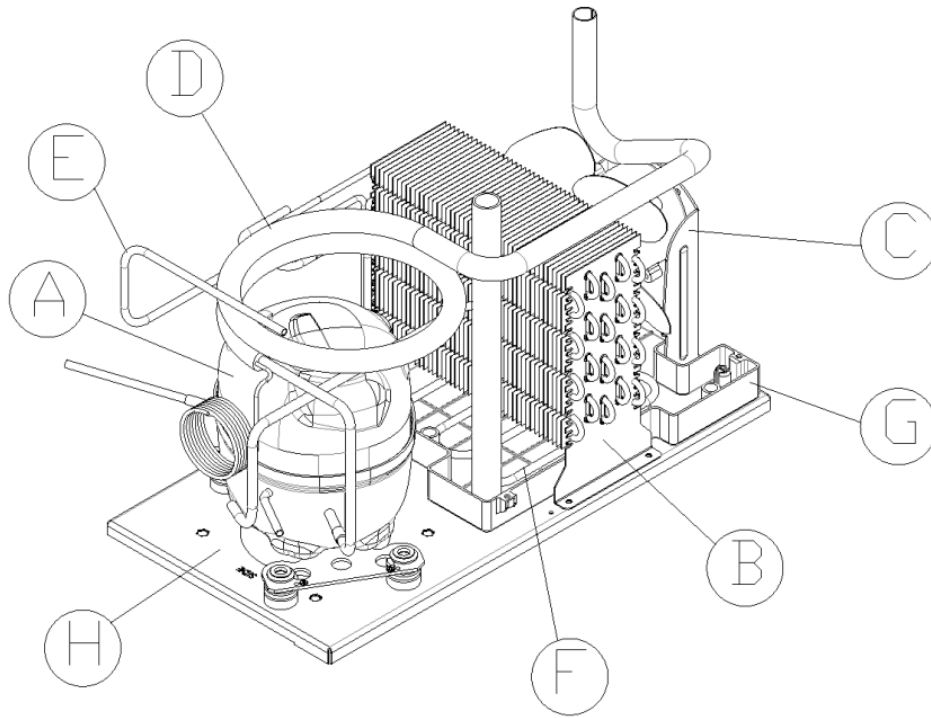

NO	Code No	Description	Qty	Material	Spec
A	R714A-540	COMPRESSOR (NF21K5131FU)	1	-	NF21K5131FU 220V/50HZ
B	R212A-070	CONDENSER WIRE(8)	1	Steel Pipe	OD4.76*0.7t
C	R831A-120	ASSY MOTOR CONDENSER	1	-	9W CW ASSY
D	R319C-360	PIPE SUCTION(LNFT)	1	CU PIPE	OD7.94+Capi
E	R319C-020	PIPE COND OUT(SIDE TABLE)	1	CU PIPE	OD4.76
F	R319B-670	PIPE CASE DRAIN(SIDE TABLE)	1	CU PIPE	OD6.35
G	R321A-811	CASE DRAIN	1	ABS	T1.5
H	R359I-190	PLATE UNIT BASE-SIDE S	1	GI	T1.6*540.4*286.9

J. R815B-090 ASSY UNIT(SC12CLX2_D600)

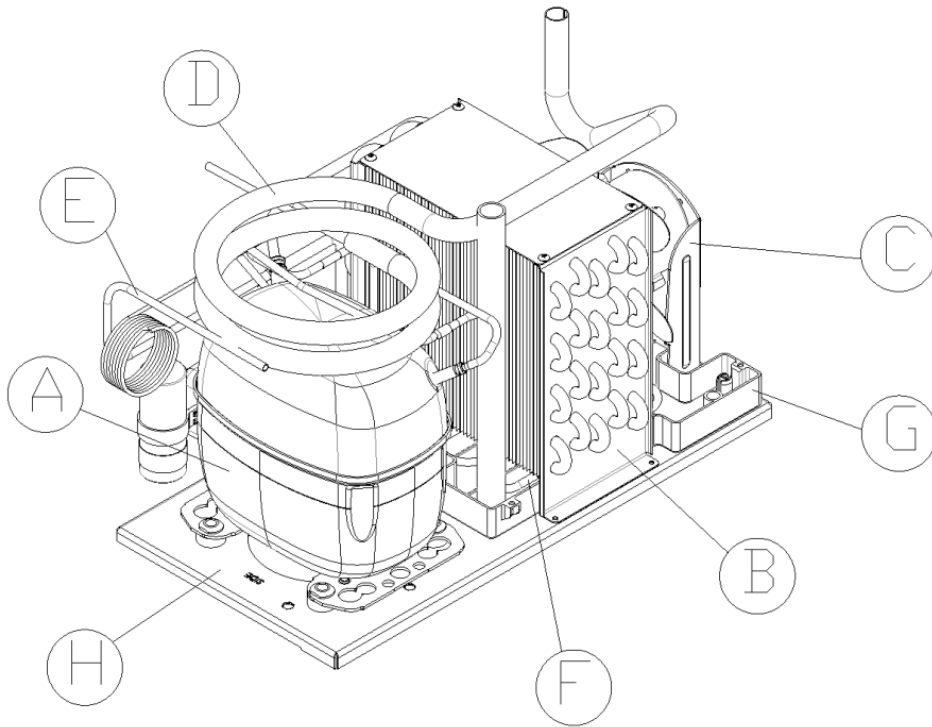

NO	Code No	Description	Qty	Material	Spec
A	R714A-030	COMPRESSOR(SC12CLX)	1	-	Danfoss R-404a, 220V/50HZ
B	R212A-070	CONDENSER WIRE(8)	1	Steel Pipe	OD4.76*0.7t
C	R8323-280	ASSY CONDENSER FAN MOTOR	1	-	9W CCW ASSY
D	R319C-370	PIPE SUCTION(SC12CLX)	1	CU PIPE	SC12CLX
E	R319C-020	PIPE COND OUT(SIDE TABLE)	1	CU PIPE	OD4.76
F	R319B-670	PIPE CASE DRAIN(SIDE TABLE)	1	CU PIPE	OD6.35
G	R321A-811	CASE DRAIN	1	ABS	T1.5
H	R359I-190	PLATE UNIT BASE-SIDE S	1	GI	T1.6*540.4*286.9

f. R8323-280 ASSY CONDENSER FAN MOTOR

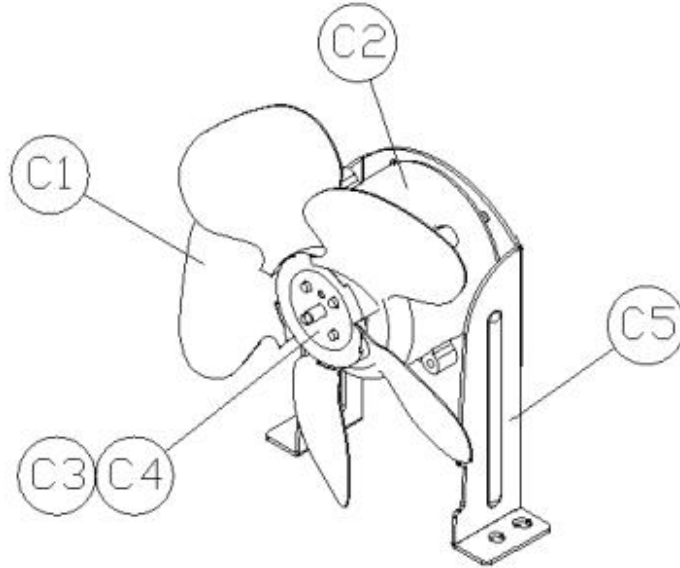

NO	Code No	Description	Qty	Material	Spec
C1	R3729-010	EVAP FAN BLADE (8 INCH. CCW)	1	AL	-
C2	R726A-080	MOTOR CONDENSER FAN (DAI-8204DYA-4)	1	-	METAL TYPE
C3	R118A-031	SPONGE MOTOR B/K	1	FOAM-PE	T4*29*48
C4	Z394A-150	SCREW MACHINE	1	SWCH-NI	TH M4*10
C5	R315A-050	BRACKET C-FAN MOTOR	1	SBHG1-0	T2.0

C. Assembly Evaporator Unit

a.Refrigerator Eva Unit

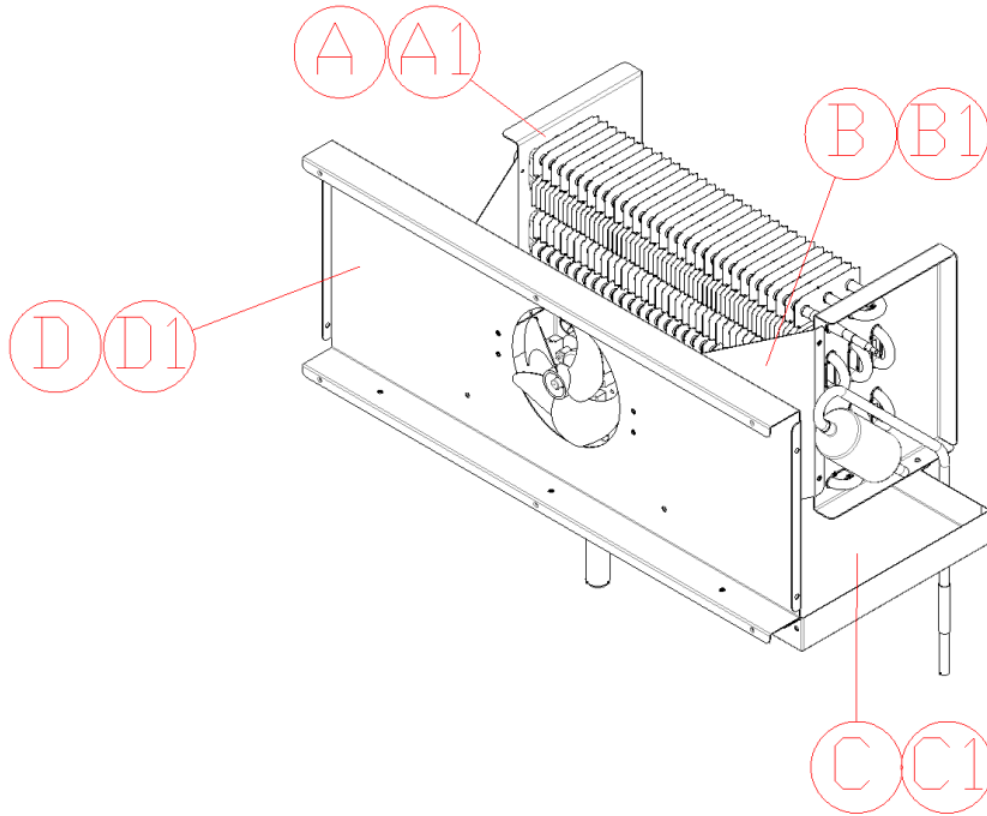

NO	Code No	Description	Qty	Material	Spec	Note
A	R214A-110	EVAPORATOR REF	1	AL	-	
A1	R840A-460	ASSY EVAPORATOR(LNRT_D600)	1	AL		D600
B	R341A-300	GUIDE AIR EVA	1	STS443CT 2B	T0.5	
B1	R341A-370	GUIDE AIR(LNRT_D600)	1	AL	T0.5	D600
C	R819A-090	ASSY DRAIN EVA(LNRT)	1	-	Refrigerator	
C1	R819A-130	ASSY DRAIN EVA(LNRT_D600)	1		Refrigerator	D600
D	R840A-170	ASSY EVA 1M(D700)	1	-	220V/50Hz	
D1	R831A-160	ASSY MOTOR EVA(LNRT_D600)	1	-	220V/50Hz	D600

b.Freezer Eva Unit(Non Heater)

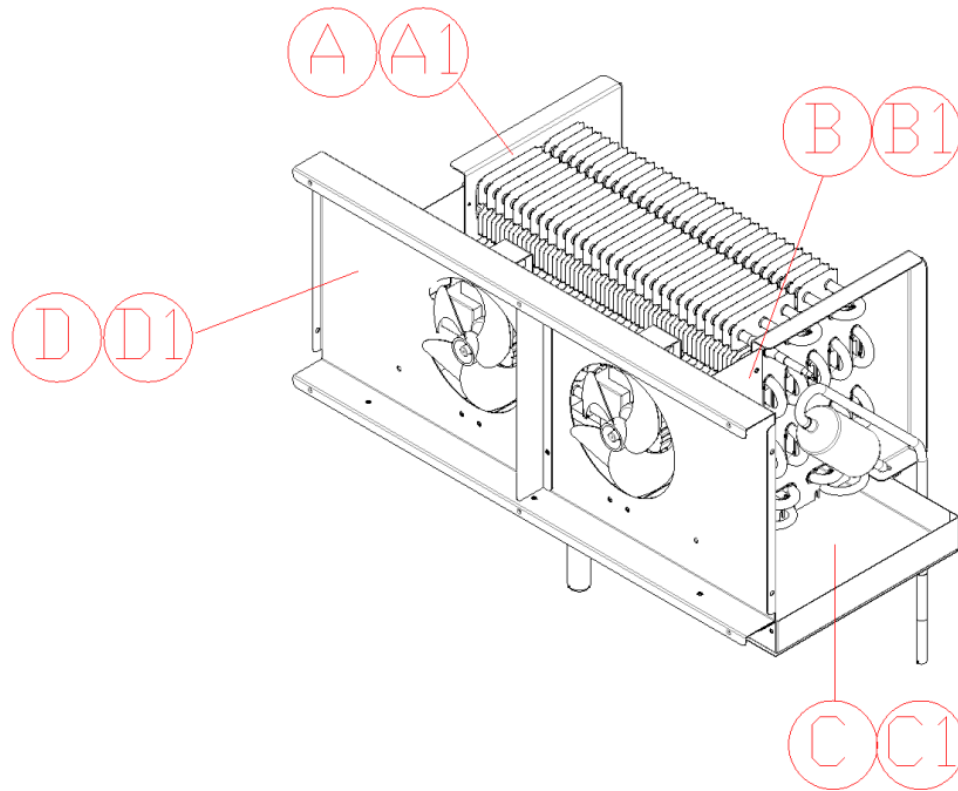

NO	Code No	Description	Qty	Material	Spec	Note
A	R214A-120	EVAPORATOR FRF	1	AL	-	
A1	R840A-470	ASSY EVAPORATOR (LNRT 1800_D600)	1	AL		D600
B	R341A-320	GUIDE AIR EVA(F)	1	STS443CT 2B	T0.5	
B1	R341A-360	GUIDE AIR(LNRT-3A-1800)	1	AL	T0.5	D600
C	R819A-090	ASSY DRAIN EVA(LNRT)	1	-	Refrigerator	
C1	R819A-130	ASSY DRAIN EVA(LNRT_D600)	1		Refrigerator	D600
D	R840A-170	ASSY EVA 1M(D700)	1	-	220V/50Hz	
D1	R831A-170	ASSY MOTOR EVA(LNFT_D600)	1		220V/50Hz	D600

C.Freezer Eva Unit(Heater_D700)

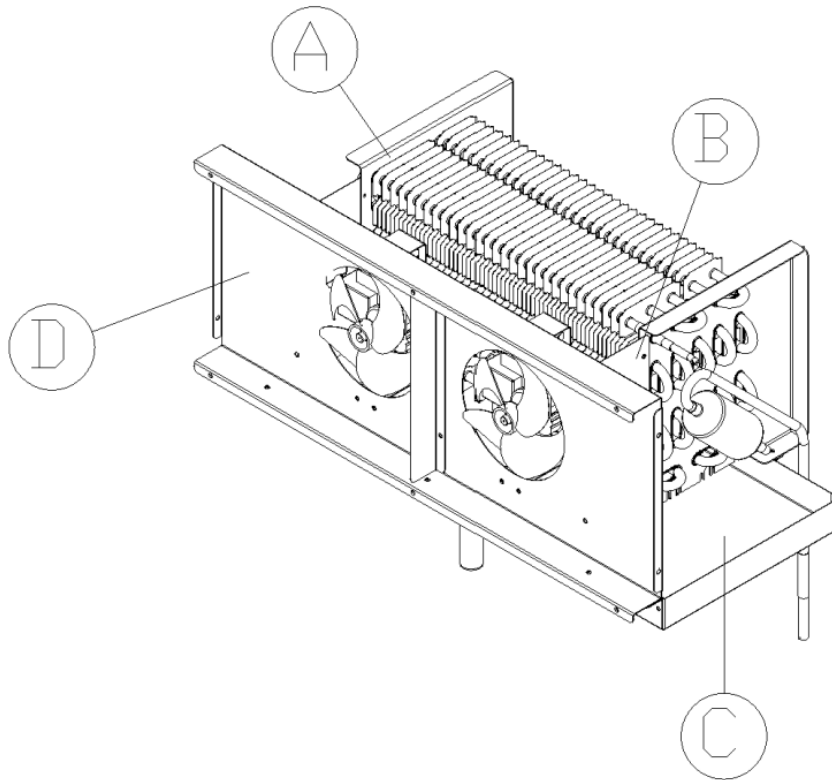

NO	Code No	Description	Qty	Material	Spec
A	R214A-120	EVAPORATOR FRF	1	AL	-
B	R341A-320	GUIDE AIR EVA(F)	1	STS443CT 2B	T0.5
C	R819A-090	ASSY DRAIN EVA(LNRT)	1	-	Refrigerator
D	R840A-170	ASSY EVA 1M(D700)	1	-	220V/50Hz

D.Freezer Eva Unit(Heater_D600)

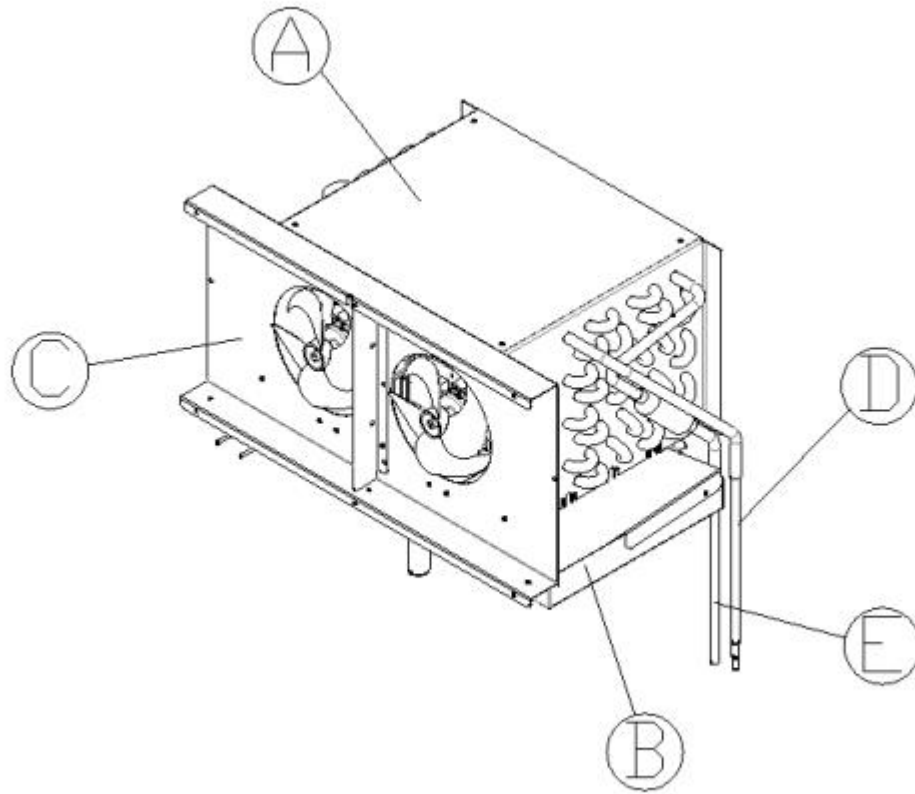

NO	Code No	Description	Qty	Material	Spec
A	R840A-480	ASSY EVAPORATOR(LNFT_D600)	1	CU	
B	R819A-150	ASSY DRAIN EVA(LNFT_D600)	1	LNFT_D600	
C	R831A-170	ASSY MOTOR EVA(LNFT_D600)	1	LNFT_D600	
D	R319C-430	PIPE EVA IN (D600_LNFT)	1	CU T0.7*OD7.94	Refrigerator
E	R319C-440	PIPE EVA OUT (D600_LNFT)	1	CU T0.7*OD7.94	220V/50Hz

D. Control Unit

a.PCB Main, PCB Display

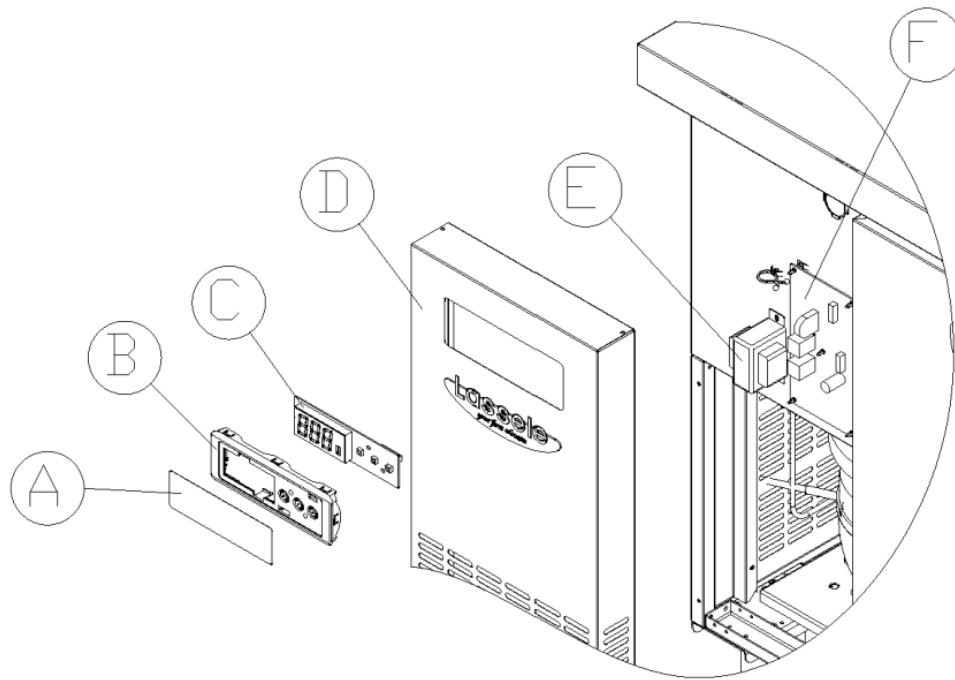

NO	Code No	Description	Qty	Material	Spec
A	R511A-540	INLAY CONTROL	1	-	Refrigerator/Freezer
B	R321A-920	CASE CONTROL PANEL	1	ABS	-
C	R725C-220	PCB PANEL	1	-	Display PCB
D	R325A-950	COVER FRONT	1	STS430 #4	T0.5
E	R738A-030	POWER TRANS (B72)	1	-	120V/60HZ DT-1215
F	R725C-210	PCB MAIN(LNRT/LNFT)	1	-	Table

E. BODY Assembly Basic Model

a.LNRT-1A/1B/1C-900, LNFT-1A/1B/1C-900

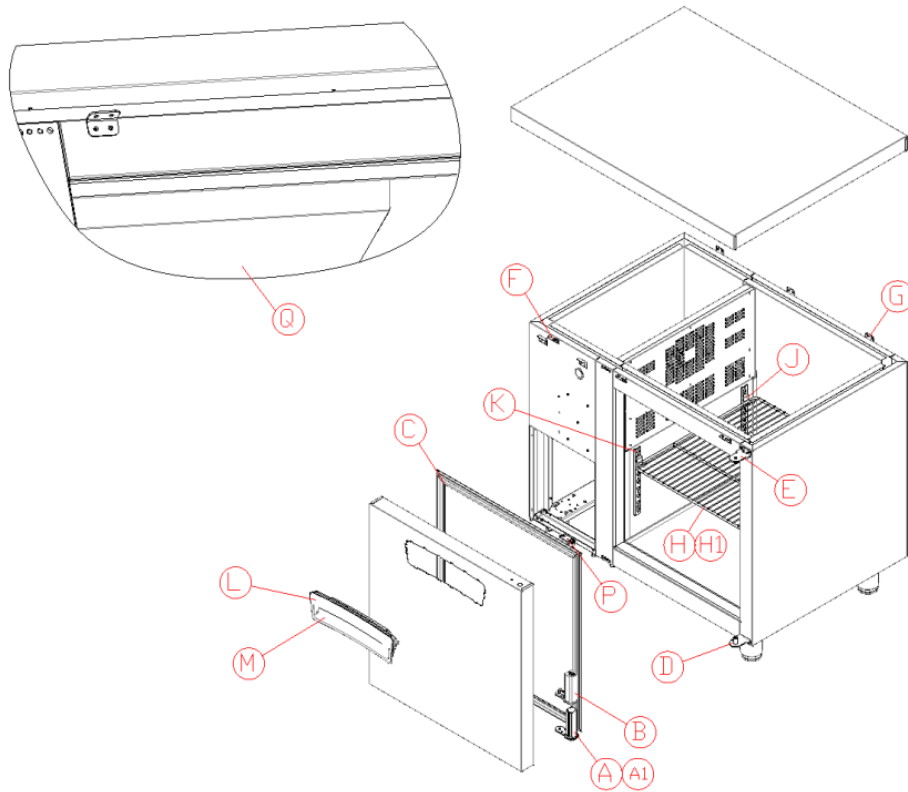

NO	Code No	Description	Qty	Material	Spec	Note
A	R828A-200	ASSY HINGE RH	1	-	LNRT-1B-900	
A1	R828A-190	ASSY HINGE LF	1	-	LNRT-1B-900L	
B	R325A-870	COVER HINGE	1	ABS	-	
C	R858F-800	GASKET DOOR-900 AS	1	PCV	T0.5	
D	R828A-170	ASSY BKT HINGE LOW	1	STS304	-	
E	R828A-180	ASSY BKT HINGE UPP	1	STS304	-	
F	R315A-630	BRACKET TABLE FRONT	3	STS430 #4	T0.8	
G	R315A-640	BRACKET TABLE TOP	3	STS430 #4	T0.8	
H	R371A-810	SHELF(NRB-90R)	1	SWRM + PE	OD6.35	
H1	R371A-900	SHELF (SALAD 900)	1	SWRM+PE	Ø6.5	D600
J	R3313-151	SHELF CLIP	4	POM	-	
K	R371A-620	SHELF STANDARD	4	AL6063S	L=230	
L	R342A-042	HANDLE COVER	1	ABS	-	
M	R342A-061	HANDLE BODY	1	ABS	-	
P	R343A-410	HINGE GROMMET	1	POM	T3.2	
Q	R332A-460	DUCT AIR TABLE(D600)	1	STS443CT	LNFT-1A-900	D600

b.LNRT-2A/2B/2C-1200, LNFT-2A/2B/2C-1200

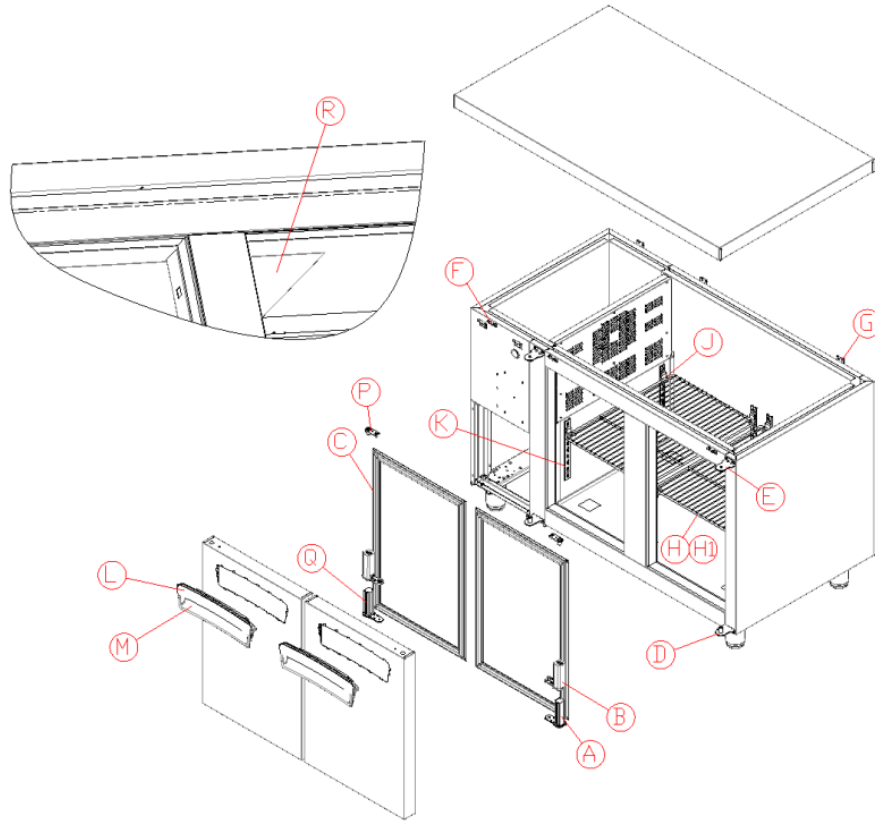

NO	Code No	Description	Qty	Material	Spec	Note
A	R828A-200	ASSY HINGE RH	1	-	-	
B	R325A-870	COVER HINGE	2	ABS	-	
C	R858F-810	GASKET DOOR-1200 AS	2	PCV	T0.5	
D	R828A-170	ASSY BKT HINGE LOW	3	STS304	-	
E	R828A-180	ASSY BKT HINGE UPP	3	STS304	-	
F	R315A-630	BRACKET TABLE FRONT	3	STS430 #4	T0.8	
G	R315A-640	BRACKET TABLE TOP	3	STS430 #4	T0.8	
H	R371A-820	SHELF(NRB-120R)	2	SWRM + PE	OD6.35	
H1	R371A-900	SHELF (SALAD 900)	1	SWRM+PE	Ø6.5	D600
J	R3313-151	SHELF CLIP	8	POM	-	
K	R371A-620	SHELF STANDARD	8	AL6063S	L=230	
L	R342A-042	HANDLE COVER	2	ABS	-	
M	R342A-061	HANDLE BODY	2	ABS	-	
P	R343A-410	HINGE GROMMET	2	POM	T3.2	
Q	R828A-190	ASSY HINGE LF	1	-	-	
R	R332A-460	DUCT AIR TABLE(D600)	1	STS443CT	LNFT-1A-900	D600

c.LNRT-2A/2B/2C-1500, LNFT-2A/2B/2C-1500

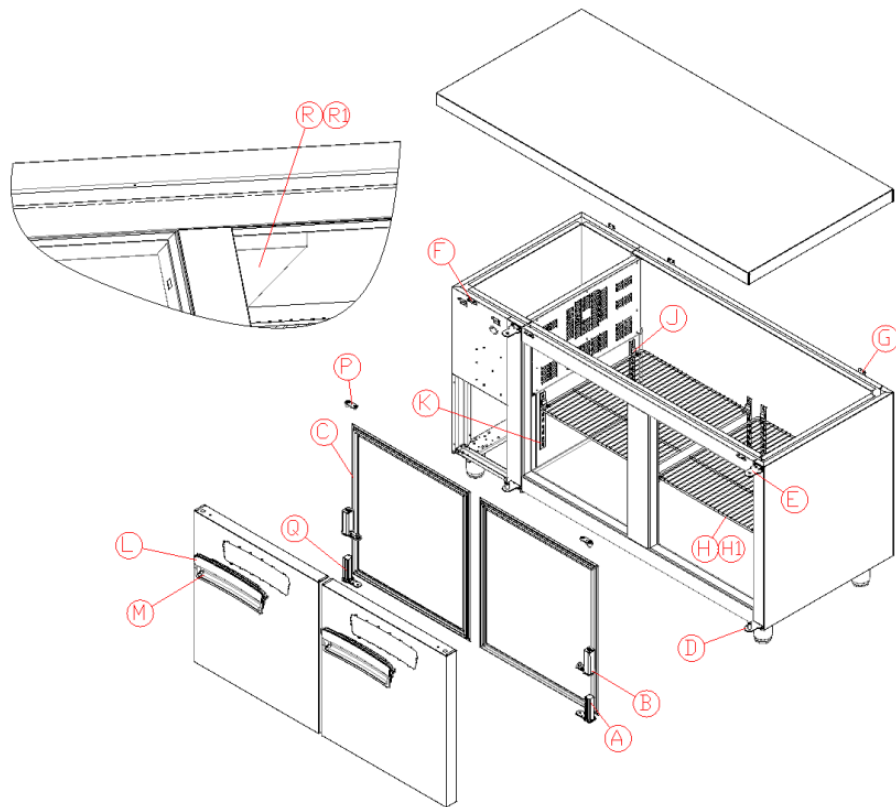

NO	Code No	Description	Qty	Material	Spec	Note
A	R828A-200	ASSY HINGE RH	1	-	-	
B	R325A-870	COVER HINGE	2	ABS	-	
C	R858D-510	GASKET DOOR-1500 AS	2	PCV	T0.5	
D	R828A-170	ASSY BKT HINGE LOW	2	STS304	-	
E	R828A-180	ASSY BKT HINGE UPP	2	STS304	-	
F	R315A-630	BRACKET TABLE FRONT	3	STS430 #4	T0.8	
G	R315A-640	BRACKET TABLE TOP	3	STS430 #4	T0.8	
H	R371A-830	SHELF(NRB-150R)	2	SWRM + PE	OD6.35	
H1	R371A-900	SHELF (SALAD 900)	1	SWRM+PE	Ø6.5	D600
J	R3313-151	SHELF CLIP	8	POM	-	
K	R371A-620	SHELF STANDARD	8	AL6063S	L=230	
L	R342A-042	HANDLE COVER	2	ABS	-	
M	R342A-061	HANDLE BODY	2	ABS	-	
P	R343A-410	HINGE GROMMET	2	POM	T3.2	
Q	R828A-190	ASSY HINGE LF	1	-	-	
R	R332A-340	AIR DUCT(1800)	1	STS443CT 2B	T0.5	
R1	R332A-450	DUCT AIR TABLE(D600)	1	STS443CT	T0.5*810.6*476.1	D600

d.LNRT-3A/3B/3C-1800, LNFT-3A/3B/3C-1800

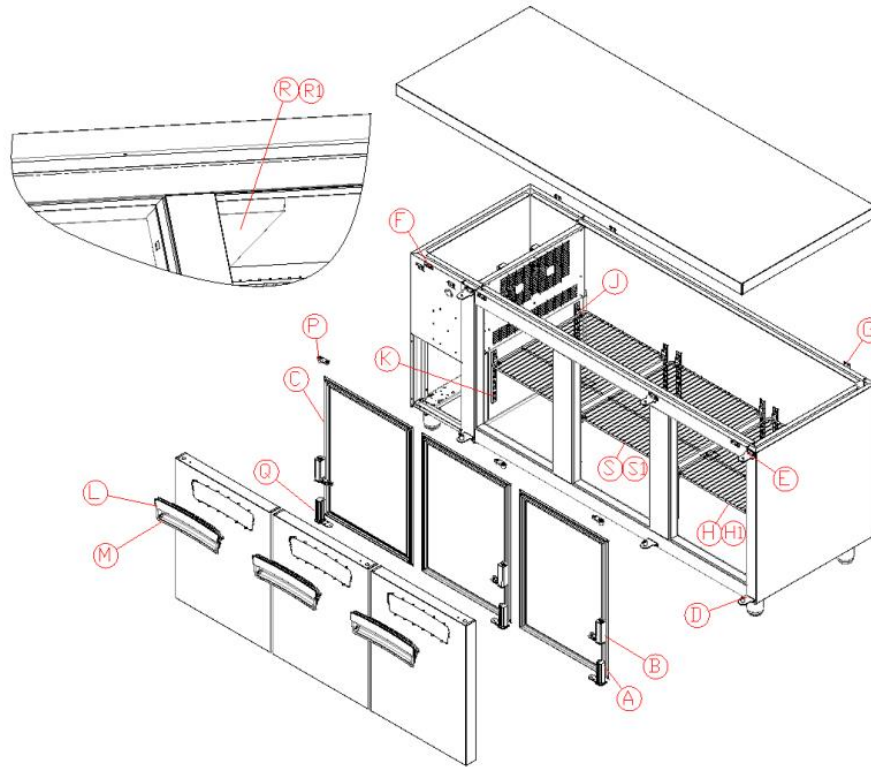

NO	Code No	Description	Qty	Material	Spec	Note
A	R828A-200	ASSY HINGE RH	2	-	-	
B	R325A-870	COVER HINGE	3	ABS	-	
C	R858F-830	GASKET DOOR-1800 AS	3	PCV	T0.5	
D	R828A-170	ASSY BKT HINGE LOW	3	STS304	-	
E	R828A-180	ASSY BKT HINGE UPP	3	STS304	-	
F	R315A-630	BRACKET TABLE FRONT	3	STS430 #4	T0.8	
G	R315A-640	BRACKET TABLE TOP	3	STS430 #4	T0.8	
H	R371A-840	SHELF(NRB-180R)	2	SWRM + PE	OD6.35	
H1	R371A-900	SHELF (SALAD 900)	1	SWRM+PE	Ø6.5	D600
J	R3313-151	SHELF CLIP	8	POM	-	
K	R371A-620	SHELF STANDARD	8	AL6063S	L=230	
L	R342A-042	HANDLE COVER	3	ABS	-	
M	R342A-061	HANDLE BODY	3	ABS	-	
P	R343A-410	HINGE GROMMET	3	POM	T3.2	
Q	R828A-190	ASSY HINGE LF	1	-	-	
R	R332A-340	AIR DUCT(1800)	1	STS443CT 2B	T0.5	
R1	R332A-450	DUCT AIR TABLE(D600)	1	STS443CT	T0.5*810.6*476.1	D600
S	R371A-810	SHELF(NRB-90R)	1	SWRM + PE	OD6.35	
S1	R371A-900	SHELF (SALAD 900)	1	SWRM+PE	Ø6.5	D600

F. BODY Assembly GN Model

a.LERT-1B-900, LERT-1C-900, LEFT-1B-900, LEFT-1C-900

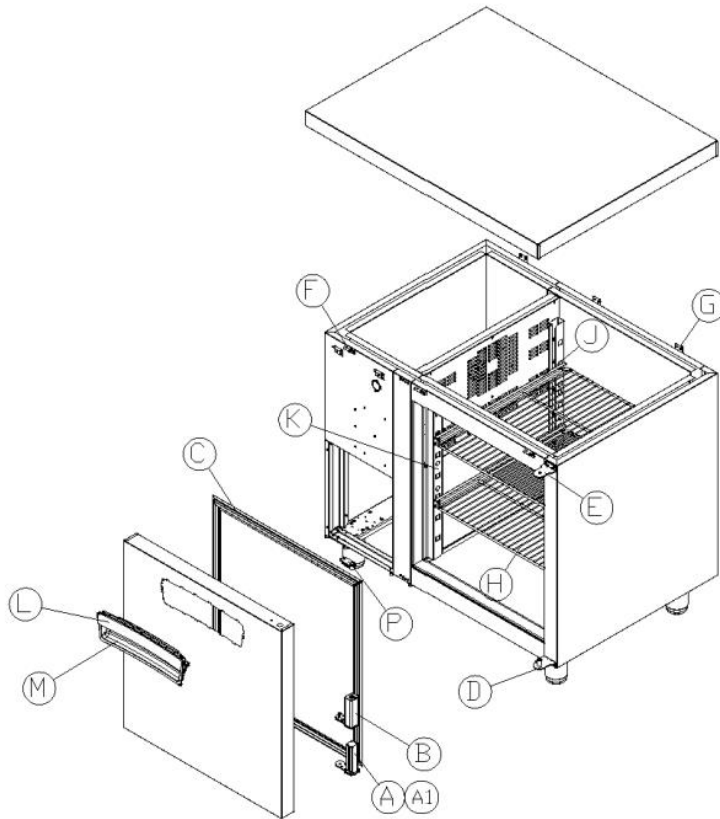

NO	Code No	Description	Qty	Material	Spec
A	R828A-200	ASSY HINGE RH	1	-	LNRT-1B-900
A1	R828A-190	ASSY HINGE LF	1	-	LNRT-1B-900L
B	R325A-870	COVER HINGE	1	ABS	-
C	R858F-800	GASKET DOOR-900 AS	1	PCV	T0.5
D	R828A-170	ASSY BKT HINGE LOW	1	STS304	-
E	R828A-180	ASSY BKT HINGE UPP	1	STS304	-
F	R315A-630	BRACKET TABLE FRONT	3	STS430 #4	T0.8
G	R315A-640	BRACKET TABLE TOP	3	STS430 #4	T0.8
H	R371A-700	SHELF(W900)_GN	2	SWRM + PE	OD6.35
J	R364A-030	RAIL_GN	4	STS430 #4	T1.0
K	R365A-660	REINFORCE SIDE_GN	4	STS430 #4	T1.0
L	R342A-042	HANDLE COVER	1	ABS	-
M	R342A-061	HANDLE BODY	1	ABS	-
P	R343A-410	HINGE GROMMET	1	POM	T3.2

b.LERT-2B-1200, LERT-2C-1200, LEFT-2B-1200, LEFT-2C-1200

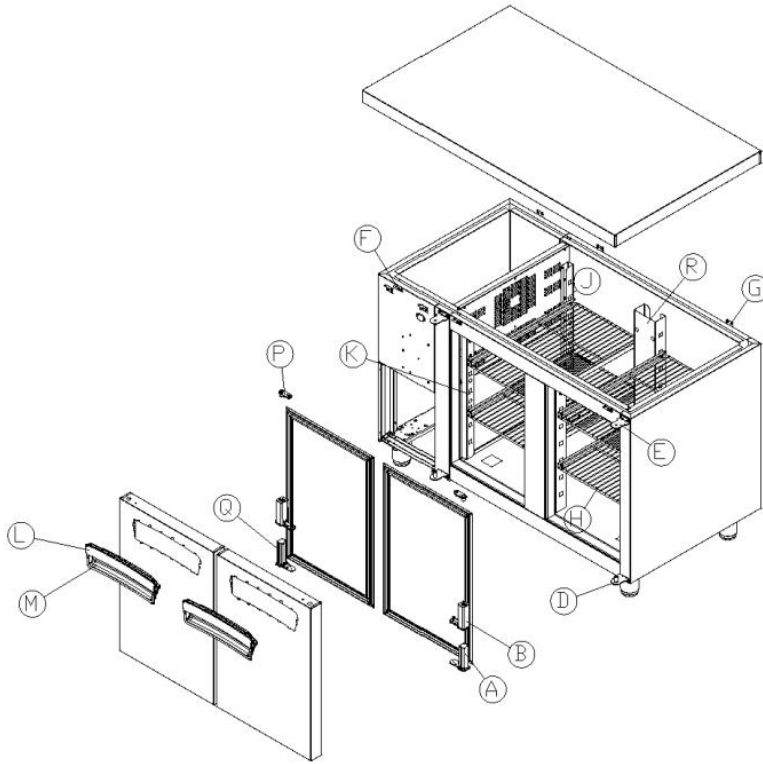

NO	Code No	Description	Qty	Material	Spec
A	R828A-200	ASSY HINGE RH	1	-	-
B	R325A-870	COVER HINGE	2	ABS	-
C	R858F-810	GASKET DOOR-1200 AS	2	PCV	T0.5
D	R828A-170	ASSY BKT HINGE LOW	3	STS304	-
E	R828A-180	ASSY BKT HINGE UPP	3	STS304	-
F	R315A-630	BRACKET TABLE FRONT	3	STS430 #4	T0.8
G	R315A-640	BRACKET TABLE TOP	3	STS430 #4	T0.8
H	R371A-730	SHELF(W1200)_GN	4	SWRM + PE	OD6.35
J	R364A-030	RAIL_GN	8	STS430 #4	T1.0
K	R365A-660	REINFORCE SIDE_GN	8	STS430 #4	T1.0
L	R342A-042	HANDLE COVER	2	ABS	-
M	R342A-061	HANDLE BODY	2	ABS	-
P	R343A-410	HINGE GROMMET	2	POM	T3.2
Q	R828A-190	ASSY HINGE LF	1	-	-
R	R365A-650	REINFORCE CROSSBAR_GN	2	STS430 #4	T1.0

c.LERT-2B-1500, LERT-2C-1500, LEFT-2B-1500, LEFT-2C-1500

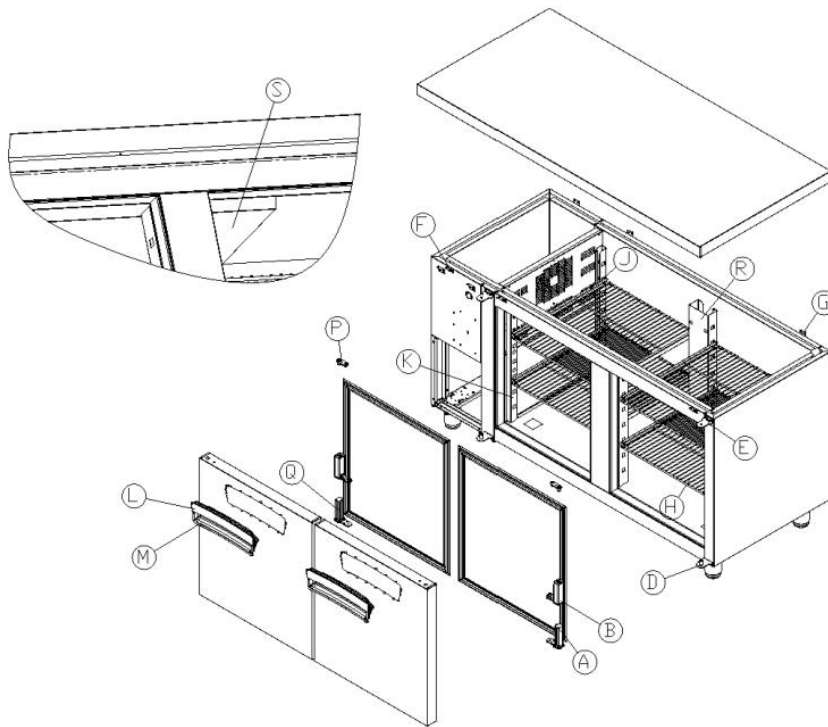

NO	Code No	Description	Qty	Material	Spec
A	R828A-200	ASSY HINGE RH	1	-	-
B	R325A-870	COVER HINGE	2	ABS	-
C	R858F-820	GASKET DOOR-1500 AS	2	PCV	T0.5
D	R828A-170	ASSY BKT HINGE LOW	2	STS304	-
E	R828A-180	ASSY BKT HINGE UPP	2	STS304	-
F	R315A-630	BRACKET TABLE FRONT	3	STS430 #4	T0.8
G	R315A-640	BRACKET TABLE TOP	3	STS430 #4	T0.8
H	R371A-760	SHELF(W1500)_GN	4	SWRM + PE	OD6.35
J	R364A-030	RAIL_GN	8	STS430 #4	T1.0
K	R365A-660	REINFORCE SIDE_GN	8	STS430 #4	T1.0
L	R342A-042	HANDLE COVER	2	ABS	-
M	R342A-061	HANDLE BODY	2	ABS	-
P	R343A-410	HINGE GROMMET	2	POM	T3.2
Q	R828A-190	ASSY HINGE LF	1	-	-
R	R332A-340	AIR DUCT(1800)	1	STS443CT 2B	T0.5
S	R365A-650	REINFORCE CROSSBAR_GN	2	STS430 #4	T1.0

d.LERT-3B-1800, LERT-3C-1800, LEFT-3B-1800, LEFT-3C-1800

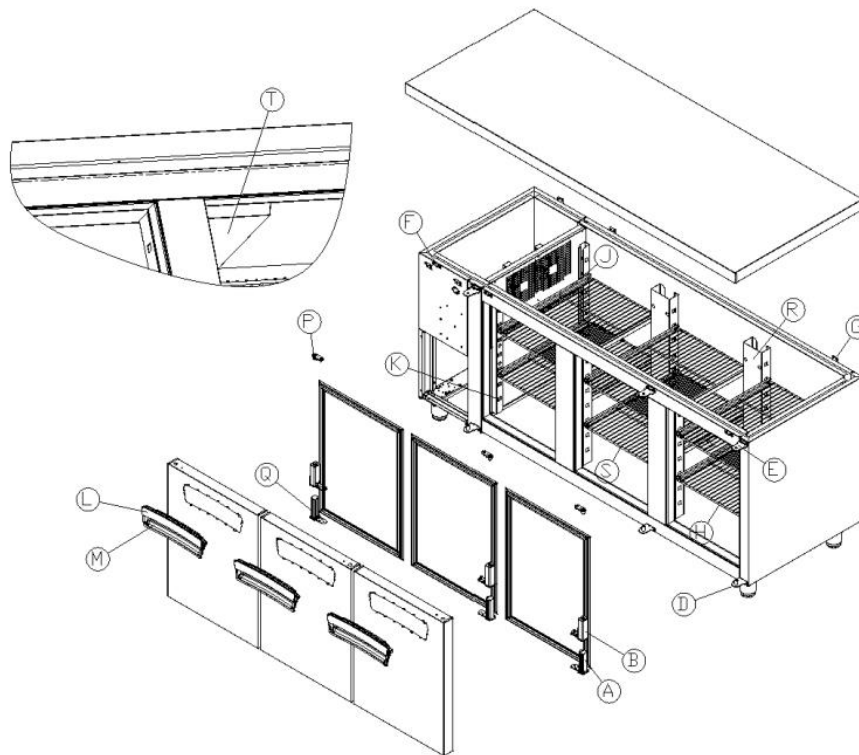

NO	Code No	Description	Qty	Material	Spec
A	R828A-200	ASSY HINGE RH	2	-	-
B	R325A-870	COVER HINGE	3	ABS	-
C	R858F-830	GASKET DOOR-1800 AS	3	PCV	T0.5
D	R828A-170	ASSY BKT HINGE LOW	3	STS304	-
E	R828A-180	ASSY BKT HINGE UPP	3	STS304	-
F	R315A-630	BRACKET TABLE FRONT	3	STS430 #4	T0.8
G	R315A-640	BRACKET TABLE TOP	3	STS430 #4	T0.8
H	R371A-790	SHELF(W1800)_GN	4	SWRM + PE	OD6.35
J	R364A-030	RAIL_GN	12	POM	-
K	R365A-660	REINFORCE SIDE_GN	12	AL6063S	L=230
L	R342A-042	HANDLE COVER	3	ABS	-
M	R342A-061	HANDLE BODY	3	ABS	-
P	R343A-410	HINGE GROMMET	3	POM	T3.2
Q	R828A-190	ASSY HINGE LF	1	-	-
R	R332A-340	AIR DUCT(1800)	1	STS443CT 2B	T0.5
S	R371A-670	SHELF MID(W1800)_GN	2	SWRM + PE	OD6.35
T	R332A-340	AIR DUCT(1800)	1	STS443CT 2B	T0.5

G. BODY Assembly Glass Model

a.LGRT-1B-900, LGRT-1C-900

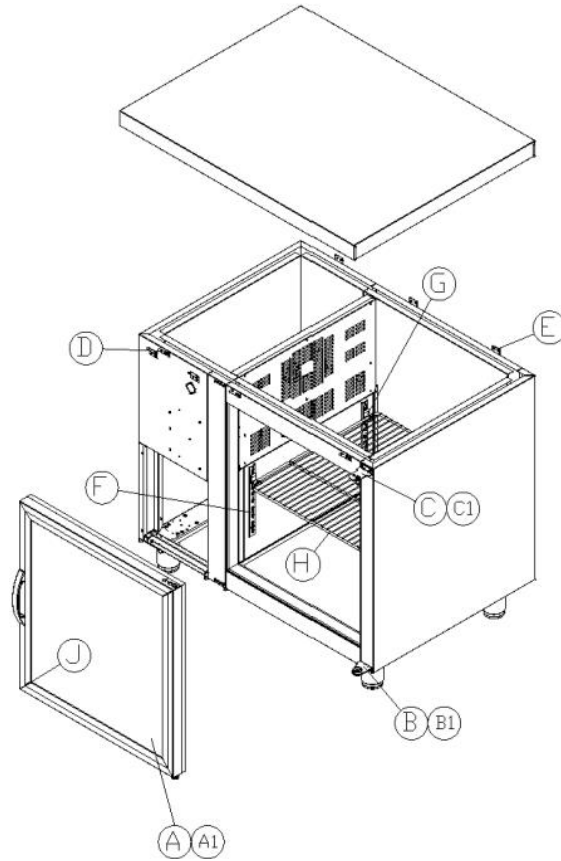

NO	Code No	Description	Qty	Material	Spec
A	R817C-230	ASSY GLASS DOOR RH(900)	1	-	-
A1	R817C-240	ASSY GLASS DOOR LF(900)	1	-	-
B	R828A-280	ASSY BRACKET HINGE LOW RH	1	-	-
B1	R828A-270	ASSY BRACKET HINGE LOW LF	1	-	-
C	R828A-300	ASSY BRACKET HINGE UPP RH	1	-	-
C1	R828A-290	ASSY BRACKET HINGE UPP LF	1	-	-
D	R315A-630	BRACKET TABLE FRONT	3	STS430 #4	T0.8
E	R315A-640	BRACKET TABLE TOP	3	STS430 #4	T0.8
F	R371A-620	SHELF STANDARD	4	AL6063S	L=230
G	R3313-151	SHELF CLIP	4	POM	-
H	R371A-810	SHELF(NRB-90R)	1	SWRM + PE	OD6.35
J	R338A-180	GASKET GLASS DOOR(W900)	1	PCV	T0.5

b.LGRT-2B-1200, LGRT-2C-1200

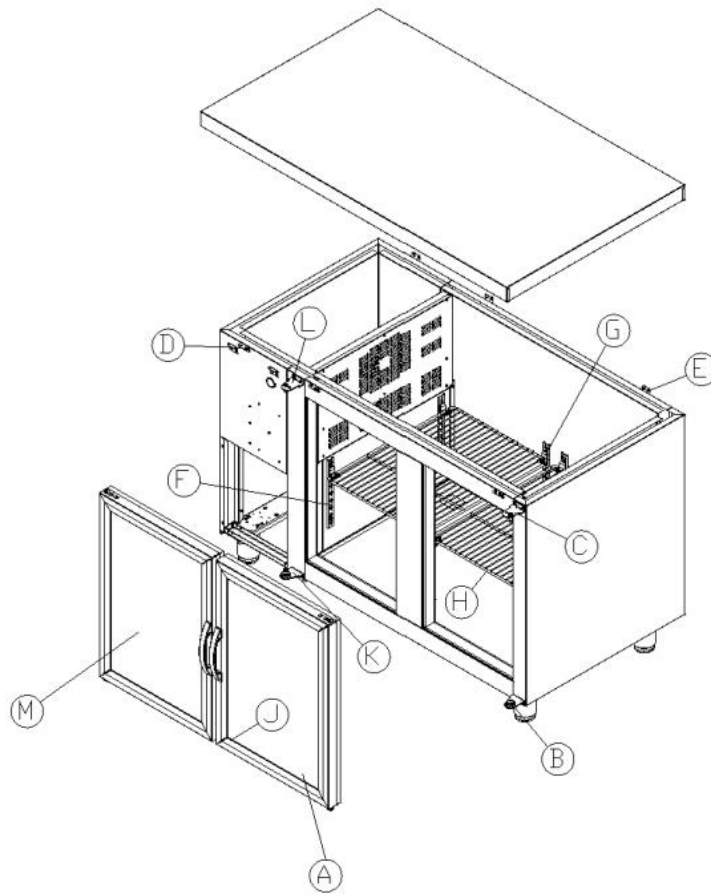

NO	Code No	Description	Qty	Material	Spec
A	R817C-250	ASSY GLASS DOOR RH(1200)	1	-	-
B	R828A-280	ASSY BRACKET HINGE LOW RH	1	-	-
C	R828A-300	ASSY BRACKET HINGE UPP RH	1	-	-
D	R315A-630	BRACKET TABLE FRONT	3	STS430 #4	T0.8
E	R315A-640	BRACKET TABLE TOP	3	STS430 #4	T0.8
F	R371A-620	SHELF STANDARD	8	AL6063S	L=230
G	R3313-151	SHELF CLIP	8	POM	-
H	R371A-820	SHELF(NRB-120R)	2	SWRM + PE	OD6.35
J	R338A-190	GASKET GLASS DOOR(W1200)	2	PCV	T0.5
K	R828A-270	ASSY BRACKET HINGE LOW LF	1	-	-
L	R828A-290	ASSY BRACKET HINGE UPP LF	1	-	-
M	R817C-260	ASSY GLASS DOOR LF(1200)	2	-	-

c.LGRT-2B-1500, LGRT-2C-1500

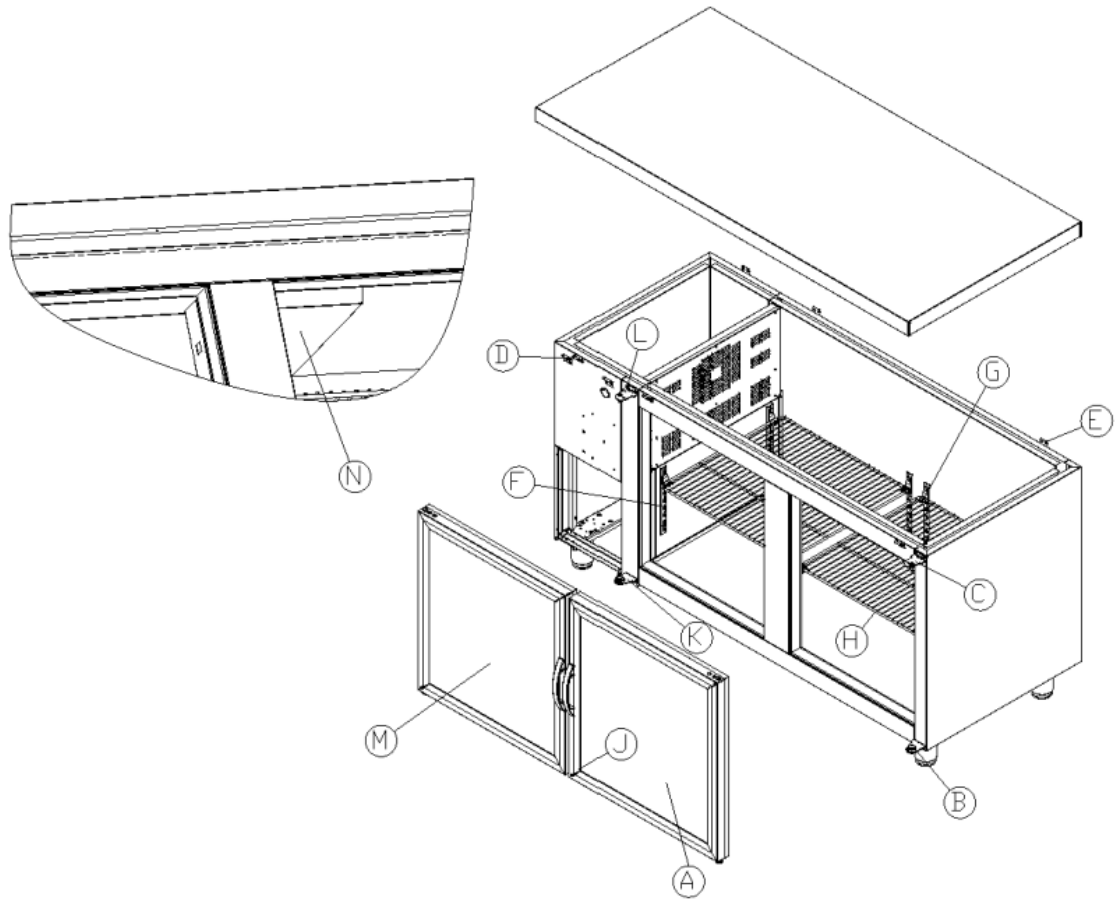

NO	Code No	Description	Qty	Material	Spec
A	R817C-270	ASSY GLASS DOOR RH(1500)	1	-	-
B	R828A-280	ASSY BRACKET HINGE LOW RH	1	-	-
C	R828A-300	ASSY BRACKET HINGE UPP RH	1	-	-
D	R315A-630	BRACKET TABLE FRONT	3	STS430 #4	T0.8
E	R315A-640	BRACKET TABLE TOP	3	STS430 #4	T0.8
F	R371A-620	SHELF STANDARD	8	AL6063S	L=230
G	R3313-151	SHELF CLIP	8	POM	-
H	R371A-830	SHELF(NRB-150R)	2	SWRM + PE	OD6.35
J	R338A-200	GASKET GLASS DOOR(W1500)	2	PCV	T0.5
K	R828A-270	ASSY BRACKET HINGE LOW LF	1	-	-
L	R828A-290	ASSY BRACKET HINGE UPP LF	1	-	-
M	R817C-280	ASSY GLASS DOOR LF(1500)	2	-	-
N	R332A-340	AIR DUCT(1800)	1	STS443CT 2B	T0.5

d.LGRT-3B-1800, LGRT-3C-1800

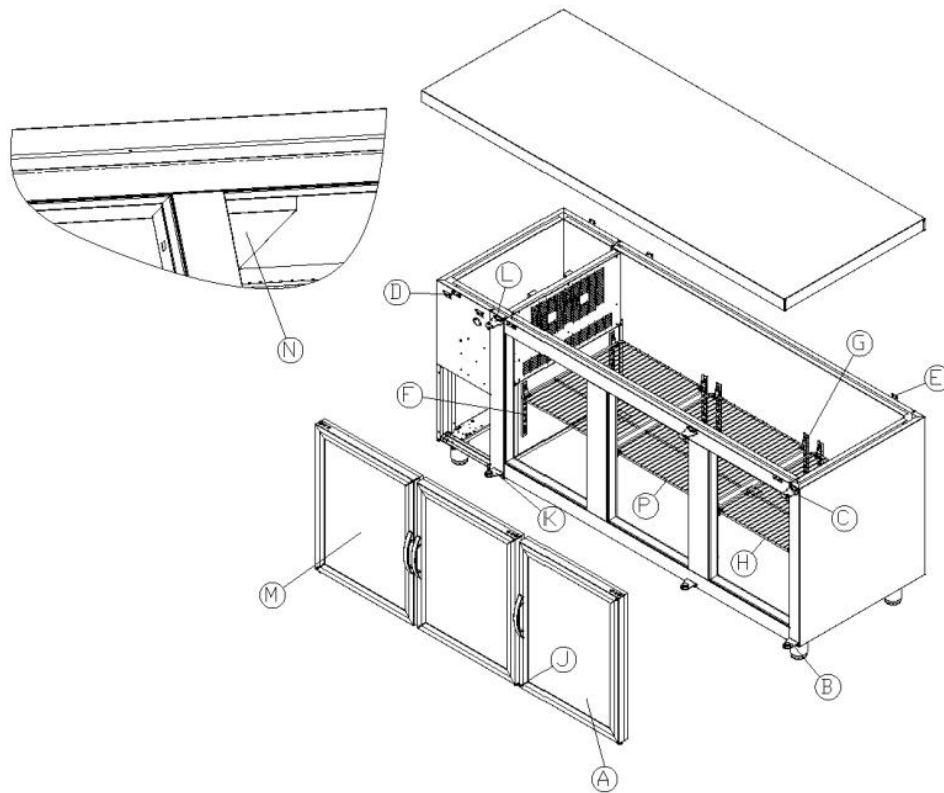

NO	Code No	Description	Qty	Material	Spec
A	R817C-290	ASSY GLASS DOOR RH(1800)	1	-	-
B	R828A-280	ASSY BRACKET HINGE LOW RH	2	-	-
C	R828A-300	ASSY BRACKET HINGE UPP RH	2	-	-
D	R315A-630	BRACKET TABLE FRONT	3	STS430 #4	T0.8
E	R315A-640	BRACKET TABLE TOP	3	STS430 #4	T0.8
F	R371A-620	SHELF STANDARD	12	AL6063S	L=230
G	R3313-151	SHELF CLIP	12	POM	-
H	R371A-840	SHELF(NRB-180R)	2	SWRM + PE	OD6.35
J	R338A-210	GASKET GLASS DOOR(W1800)	3	PCV	T0.5
K	R828A-270	ASSY BRACKET HINGE LOW LF	1	-	-
L	R828A-290	ASSY BRACKET HINGE UPP LF	1	-	-
M	R817C-300	ASSY GLASS DOOR LF(1800)	2	-	-
N	R332A-340	AIR DUCT(1800)	1	STS443CT 2B	T0.5
P	R371A-810	SHELF(NRB-90R)	1	SWRM + PE	OD6.35

3. WIRING DIAGRAM

- a. **LNRT-1A/1B/1C-900/900L**, LERT-1B/1C-900/900L, LGRT-1B/1C-900/900L
LEGRT-1B/1C-900/900L, **LNRT-2A/2B/2C-1200**, LERT-2B/2C-1200, LGRT-2B/2C-1200
 LEGRT-2B/2C-1200, **LNRT-2A/2B/2C-1500**, LERT-2B/2C-1500, LGRT-2B/2C-1500
 LEGRT-2B/2C-1500

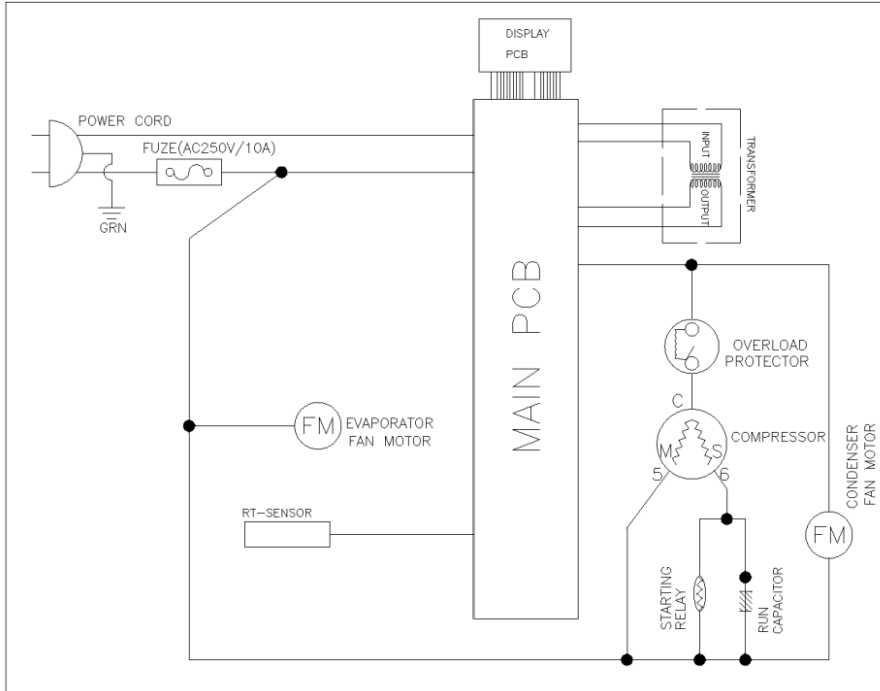

- b. **LNRT-3A/3B/3C-1800**, LERT-3B/3C-1800, LGRT-3B/3C-1800, LEGRT-3B/3C-1800

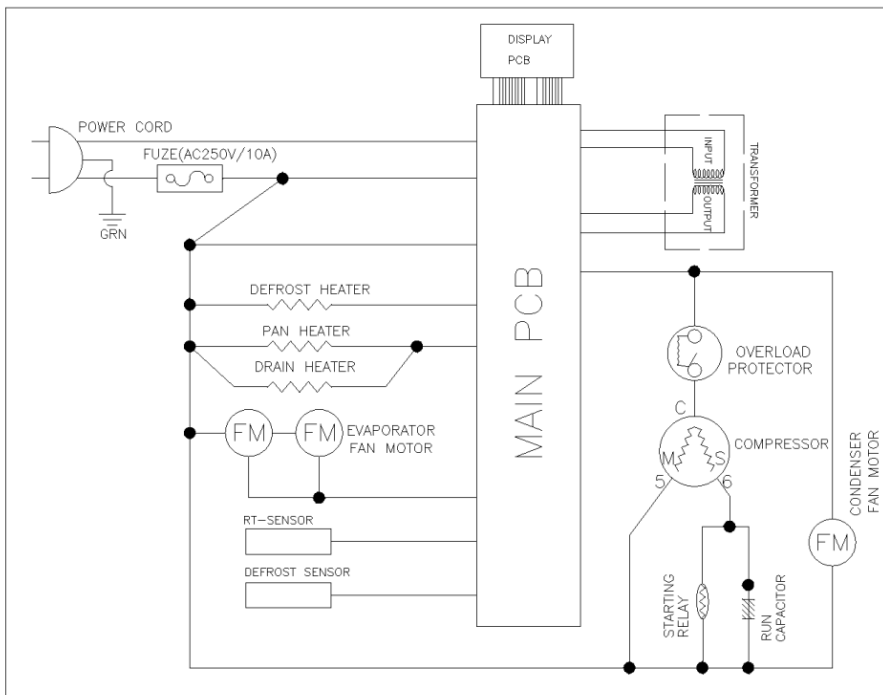

c. LNFT-2B/2C-1200, LERT-2B/2C-1200

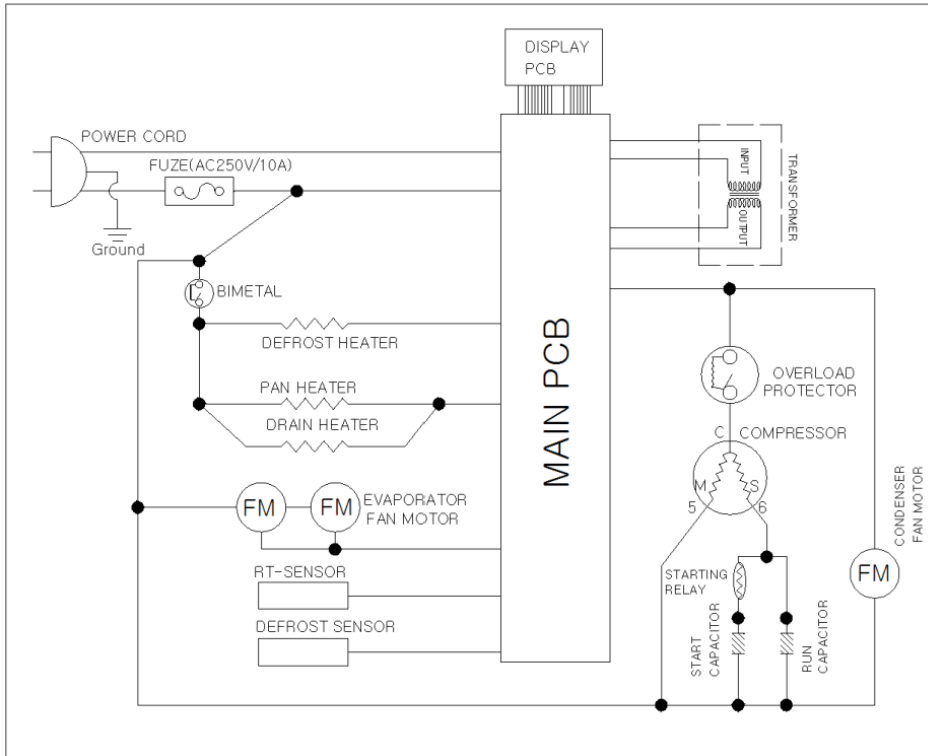

d. LNFT-2A/2B/2C-1500, LERT-2B/2C-1500,
LNFT-3A/3B/3C-1800, LERT-3B/3C-1800

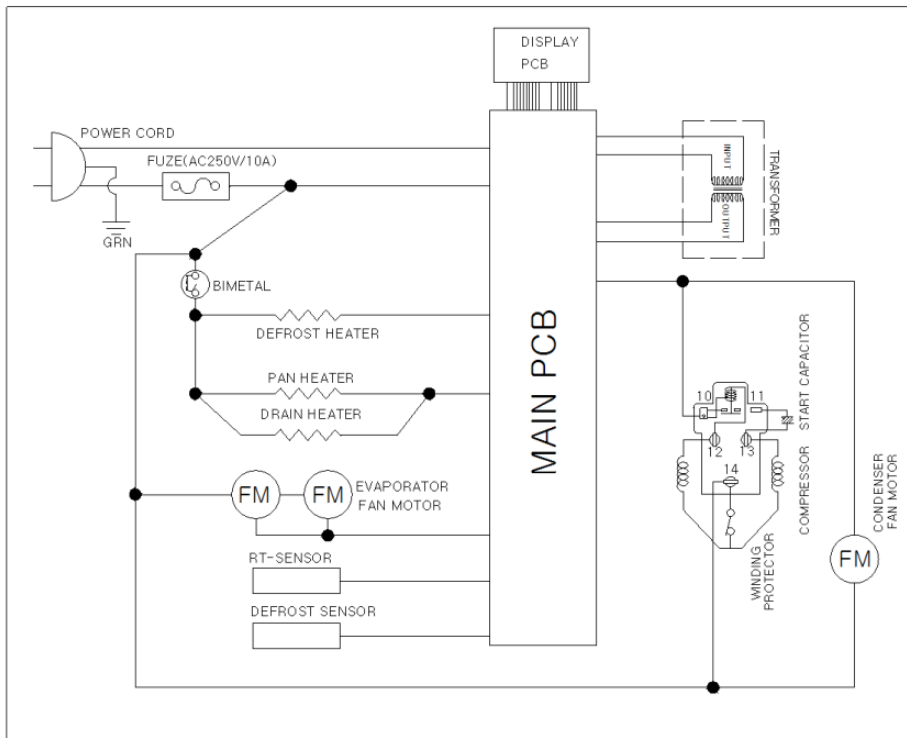

e. LNFT-1A/1B/1C-900/900L, LNFT-2A-1200 LEFT-1B/1C-900/900L

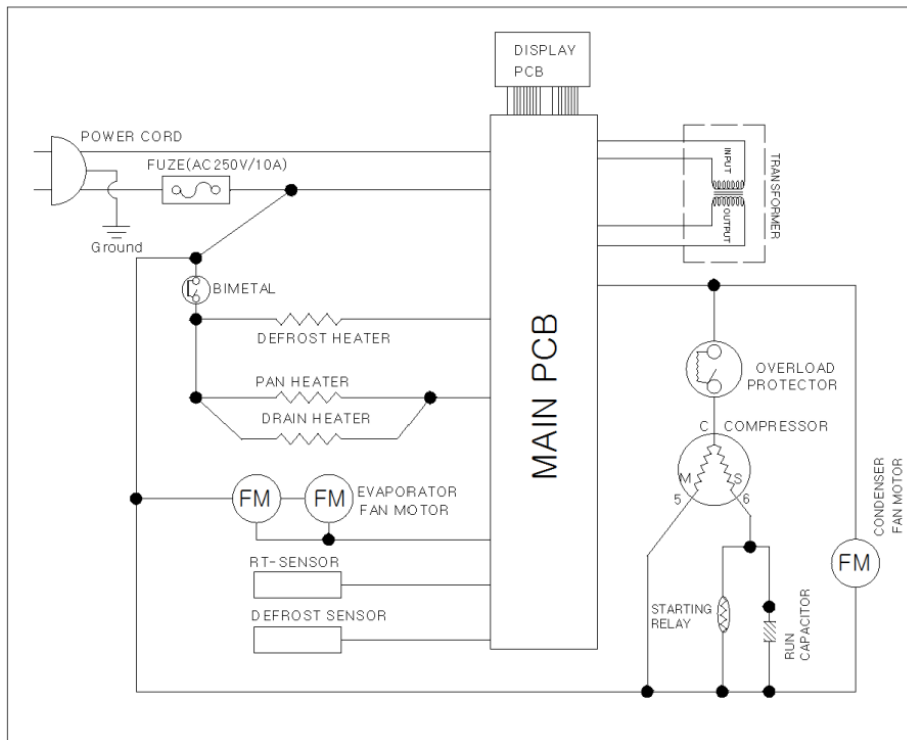

4. ELECTRONIC CONTROL INSTRUCTIONS

A. How to use the display PCB panel

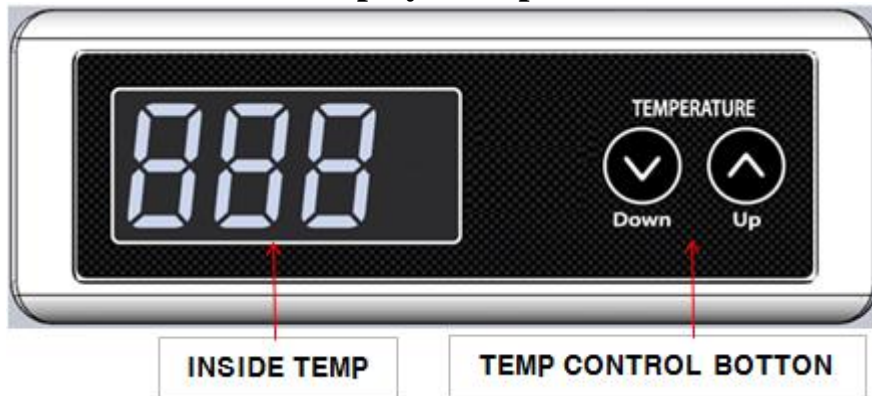

a. Up / Down Button(Temperature Control Button)

- By Pushing the up/down button, you can see the cabinet temperature

B.Freezer Control

a.Funtion Table & Manual Defrost

NO	Function	Content	Display
1	Power On	<ol style="list-style-type: none"> 1. OFF for 2 sec 2. Displaycurrent Temp. and BUZZ 1 time. 3. Eva sensor Temp. over 41°F(5°C) : Operate under 41°F(5°C) : Operate after 5 min 	<p>. First 2 sec Ver. °F : F8, °C : FC After 2 sec Present °C/°F</p>
2	Front Key	<ol style="list-style-type: none"> 1. Push △/▼to change Temp. (Each time you push, 1 buzz sound.) 2. The set-up is memorized in the EEPROM and remains even after Power Off. 	<p>. Hit △/▼ 1 time - Display final set 2 times - Change set-up value</p>
3	COMP	<ol style="list-style-type: none"> 1. Operate by Temperature Value 2. Operates on Comp ON/OFF Set Value 3. If Temp. Value hits the OFF Temp. the Comp. does not operate for 5 min 	
4	FAN	<ol style="list-style-type: none"> 1. Operate with Comp. 2. If the door opens, the fan stops. 	

5	BOX HEATER	<p>1. Temp Sensor over 78°F(26°C):Box Heater Relay On. 2. Temp Sensor under 78°F(26°C). Box Heater Operates by each mode - 1. 1MODE : 10 min on/ 10 min off - 2. 2MODE : 15 min on/ 10 min off - 3. 3MODE : 20 min on/ 10 min off(Default) - 4. 4MODE : 25 min on/ 15 min off 3. Push ▼ 5 sec to display Mode. Hit ▼ to change Mode 4. First Cycle operates by 1 Mode</p>	72R
6	Lamp	<p>1. Door Open - LED Lamp Off Door Close - LED Lamp On 2. Maximum 2 Lamps can be Controlled.</p>	
7	Defrost	<p>1. If the defrost period passes defrost starts from pre-cool. 2.- 1. 5H : 5 Hr - 2. 6H : 6Hr - 3. 8H : 8 Hr(DEFAULT) - 4. AH : 10Hr 3. Push △ for 5 sec to display defrost period 4. Hit △ to get the Value desired</p>	
8	PRE-COOL	<p>1. Operate for 30 min, before defrost heater on 2. If Temp. goes under -12°F(-24.6°C) in 30 min defrost heater goes on mode</p>	. Displays Temp.
9	HEATER ON	<p>1. Operate after Pre-Cool 2. If the defrost sensor reaches 12°C defrost completes and heater goes Off 3. Heater on goes maximum 40 min 4. If fails, defrost Error Code will be saved. If Temp. is over 23°F(-5°C) after precool, or the sensor malfunctioned, heater will go at least 20 min and at 28°F(-2°C) it will go Off</p>	. dF
10	Resting Period	<p>1. After heater is Off there is a 5 min resting period.</p>	. dF

11	Forced Defrost	<ol style="list-style-type: none"> 1. Push \triangle & \blacktriangledown for 3 Sec at the same time. 2. Push \triangle & \blacktriangledown for 3 Sec at the same time during Defrost for cancel 	
12	Self Check	<ol style="list-style-type: none"> 1. Push \blacktriangledown & hit \triangle 3 times 2. Error Display D1 : D-Sensor Error F3 : Defrost Error C1 : Cycle Error 3. Return if nothing has done for 15 sec 	
13	Door Open and Alarm	<ol style="list-style-type: none"> 1. Door Open LED will blink until closer every 0.5 sec. 2. When Door is open over 3 min, Buzzer will chirp every 0.5 sec until closer. 	
14	D-Sensor Check	<ol style="list-style-type: none"> 1. Sensor Temp. Check & Set-up <ol style="list-style-type: none"> 1) Push \triangle & hit \blacktriangledown 3 times. 2) 1. dS : Displays D-Sensor \rightarrow hit \blacktriangledown 2. D-Sensor Temp \rightarrow hit \blacktriangledown 3. rS : Displays R-S \rightarrow hit \blacktriangledown 4. R-Sensor Temp \rightarrow hit \blacktriangledown 5. Return(return to last status. Displays current Temp or dF(Defrost) <ul style="list-style-type: none"> - After access return after the last procedure - Return after 20 min auto(D-Sensor display) 	<ul style="list-style-type: none"> . dS . 888(D-Sensor) . rS . 888(R-Sensor)
15	Condenser Alarm	<ol style="list-style-type: none"> 1. Alarms for an hour if set-up period is passed.. 2.1) Push \triangle & hit \blacktriangledown 3 times 2) dS : Displays D-Sensor \rightarrow hit \triangle <ul style="list-style-type: none"> - 0 :Disabled. - 3 : 3 months - 6 : 6 months(Default) - 9 : 9 months 3) Hit \triangle to get the Value desired. 4) .Alarms every 1 sec for an hour. 5) Return <ul style="list-style-type: none"> - Power On after Off - Push \triangle & \blacktriangledown at the same time for 3 sec 	<ul style="list-style-type: none"> ."CL"

b. Error Code Table

Display	Condition	Temp. Display	Function
CO	R-Sensor OPEN	CO	- Comp ON : 18 MINUTES - Comp OFF: 6 MINUTES 28.4°F
CS	R-Sensor SHORT	CS	
D1	D-Sensor OPEN/SHORT	Room Temp Displayed	- If R-Sensor is above 28.4°F 20 min. after the Defrost started, terminate the Defrost.
F3	Poor Defrost (If D-Sensor lower than 53.6°F in 40 min. later)		- Terminate the Defrost 40 min. after its start.
C1	Poor Cycle (If D-Sensor is above 32°F in 30 min later.		- Normal Operation
	RT-Sensor OPEN/SHORT		- BOX HEATER 100% On (72R)

c. Sensor Description

Sort	Name & Function	WAFER Color
D-sensor	. Defrost Sensor . HEATER ON/OFF CONTROL during Defrost.	WHITE
R-sensor	. Room Sensor . DISPLAY & COMP ON/OFF CONTROL	YELLOW
RT-sensor	. Room Temp Sensor . BOX HEATER Control for energy efficiency	BLUE

C. Refrigerator Control

a.Funtion Table

NO	Function	Content
1	Power On	<ul style="list-style-type: none"> - OFF for 2 sec - First 2 sec Ver.°F : F8, °C : FC - After 2 sec Present °C/°F - Blinks Model name 5 times. - LED blinks 3 times. - Present °C/°F.
		<p>2. Defrost Check</p> <p><F Model> : LFT-23S, LFT-49D</p> <ul style="list-style-type: none"> - Defrost Sensor Operation <ol style="list-style-type: none"> 1) COMP On above 38°F(3.5°C) 2) Defrost On,under 38°F(3.5°C) ※After 5min COMP delay pre-cool operate before defrost. <p><R Model> : LRT-23S, LRT-49D</p> <ul style="list-style-type: none"> - Room Sensor Operation. <ol style="list-style-type: none"> 1) COMP Onabove 41°F(5.0°C) 2) Defrost On,under 41°F(5.0°C)
2	Normal Operation	<ul style="list-style-type: none"> - COMP 5min delay (COMP OFF for 5 min) - COMP ON/OFF byRoom Sensor Temp.
3	FRE. Defrost Period	<ul style="list-style-type: none"> - Defrost Period can be set to 5/6/7/8/9/10Hr - Default 8hr
4	REF Defrost Period	<ul style="list-style-type: none"> - Defrost every 5 Hr.
5	Defrost System -FRE. Defrost System 1. PRE-COOL	<ul style="list-style-type: none"> - To Lower Room Temp. before HEATER ON - When Defrost Period, PRE-COOL on before HEATER ON - HEATER ON if Temp. is under 17°F(-8°C) in 45min - Maximum PRE-COOL time is 45min
	2. HEATER ON	<ul style="list-style-type: none"> - If the defrost sensor reaches 51°F/11°C defrost completes andheater goes Off - Heater on goes maximum 50 min. - When Defrost SENSOR ERROR, HEATER is on for20min. HEATEROFF when Temp. is 28°F(-2°C) - When Defrost Sensor / Room Sensor error HEATER is on for20min - If HEATER ON goes maximum 50minand does not reach the Defrost Return Temp. ERROR CODE will be saved. ※This ERROR Occurs Pre-COOL disable

5	3. Resting Period	-After heater is Off there is a 5 min resting period. -HEATER, FAN, COMP ALL OFF.
	4. FAN Off	-After Resting Period FAN is off for Maximum 5min. -Only COMP Operates for the EVA - If Temp. is under 14°F(-10°C) before 5 min, FAN will go off and activate normal operation.
6	REF. Defrost System	- Operate FAN for Defrost. - If Air Sensor ERROR, Defrost for 30 min and return. - After 30min Defrost, Air Sensor displays return Temp. - When Temp. reaches the return temp. normal operation. ※When Set-up Temp. is under 30°F(-1°C), Return Temp. is 37°F(+3°C) When Set-up Temp. is above 32°F(0°C) Return Temp. is 41°F(5°C).
7	HTR Control (BOX HTR)	- When COMP ON POINT Temp. is higher than RT Temp. HTR goes OFF. - When RT Temp. is above 78°F(26°C) HTR is On. - When RT Temp. is between 78°F(26°C)~Comp On Temp., HTR is 10min ON 10min OFF - When RT Temp. is below Comp On Temp. HTR goes OFF.
8	REF. Frost Prevent System	- COMP OFF → EVA FAN OFF. - To prevent REF. EVA Frost, If Room Temp. is under 32°F(0°C) FAN activates.
9	Door Open and Alarm	1. Door Open LED will blink until closer every 0.5 sec. 2. When Door is open over 3 min, Buzzer will chirp every 0.5 sec until closer.
10	FAN	1. Operate with Comp. 2. If the door opens, the fan stops.
11	Lamp	1. Door Open - LED Lamp Off Door Close - LED Lamp On - Door Error : LED Lamp Off
12	VaporPan ERROR Display	- Vapor fan ERROR : beeping sounds with SEGMENT blinks Temp.(3sec) -uFn(0.5sec) repeat. - Beeping sounds goes for 5min. -VaporPan ERROR can be disabled or enabled by OPTION.
13	Condenser Alarm	- Alarms for an hour if set-up period is passed.. - Alarms goes on with SEGMENT "CL". - Alarms every 1 sec for an hour. - Return : Power On after Off, Push △ & ▼ at the same time for 3 sec

D. Operation

a. Comp Operation

- 1) COMP 5 minOFF (COMP disabled for 5 min)
- 2) Operate by Temperature Value.
- 3) If Temp. Value hits the OFF Temp. the Comp. does not operate for 5 min.

b. AC Load Control

- 1) EachPart does not operate together, each operate by a 1.5 sec term.

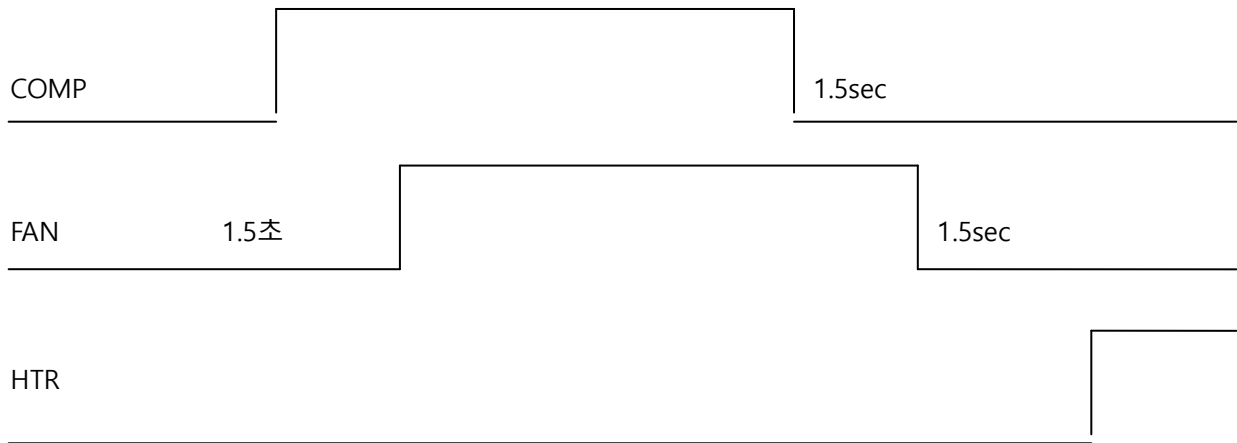

Push Δ/∇ KEY.for 3 sec to enter control mode

888SEGMENT

S	E	L
---	---	---

NO	MODE	SW 4(Δ)	Display	Content
1	Forced Defrost	1 times	ds	Display after 2 sec (888 SEGMENT & LED OFF.)
2	Mode Control	2 times	OF	
3	Each part TEST	3 times	St	
4	Error Check	4 times	no	
5	Ver. Change	5 times	23F	
6	$^{\circ}$ C/ $^{\circ}$ FChange	6 times	F	
7	Cabinet Heater	7 times	Ht	
8	LED check & E ² PROM clear	8 times	LED blinks	

c. Forced Defrost

- 1) Display : 888SEGMENT- "ds"
- 2) Content : ① Press SW3(▽) during 1) to Force Defrost.
② 888 SEGMENT - "dF"

d.Mode Control

- 1) Display : 888 SEGMENT.

0	F
---	---

 After 1 sec

0	0
---	---

- 2) Content : Press SW(△) to change mode - OFF Temp.-> DIF Change -> Adjust Temp.gap -> Defrost Time Change.

- ① OF 1 sec00 : 23°F(-5.0)~41°F(+5.0) - 32°F(0.5°C) change
(32°F(0.5°C)->32(5) Display)
- ② 0d 1 sec20 : 32(0.25) -> 32(0.5) -> 33(0.75) -> 33(1.0) -> 34(1.5) -> 35(2.0) -> 37(3.0)->
39(4.0) -> 41(5.0)
- ③ CA 1 sec00 : 23°F(-5.0)~41°F(+5.0) - 33°F(1°C) change
(Room Temp. gap adjustment)
- ④ dt 1 sec6 :FRE. Defrost Time (0, 5 ~ 10 Hr)-1HrChange
(0 :Disable)
REF. Defrost Time (0,5~10 Hr)- 1HrChange

- SW(▽) button for adjustment.
- Auto-save for change in the set-up.
- 15sec auto return.

e.Each part TEST

- 1) Display : 888SEGMENT- "St"
- 2) Content :Press SW4(△) 0~3 Mode Change.
- 3) Each part TEST Cancel : 15sec auto return.

단계	Function	Time	DISPLAY	비고			
0	All OFF	10sec auto return	<table border="1" style="display: inline-table; vertical-align: middle;"><tr><td style="width: 20px; height: 20px;"></td><td style="width: 20px; height: 20px; text-align: center;">S</td><td style="width: 20px; height: 20px; text-align: center;">t</td></tr></table>		S	t	
	S	t					
1	COMP ON FAN ON	∞	<table border="1" style="display: inline-table; vertical-align: middle;"><tr><td style="width: 20px; height: 20px;"></td><td style="width: 20px; height: 20px; text-align: center;">C</td><td style="width: 20px; height: 20px; text-align: center;">P</td></tr></table>		C	P	
	C	P					
2	COMP OFF FAN OFF Defrost HTR ON	∞	<table border="1" style="display: inline-table; vertical-align: middle;"><tr><td style="width: 20px; height: 20px; text-align: center;">d</td><td style="width: 20px; height: 20px; text-align: center;">H</td><td style="width: 20px; height: 20px; text-align: center;">t</td></tr></table>	d	H	t	R Model does not have function
d	H	t					
3	COMP OFF FAN OFF Defrost HTR OFF Cord HTR ON	∞	<table border="1" style="display: inline-table; vertical-align: middle;"><tr><td style="width: 20px; height: 20px; text-align: center;">C</td><td style="width: 20px; height: 20px; text-align: center;">H</td><td style="width: 20px; height: 20px; text-align: center;">t</td></tr></table>	C	H	t	
C	H	t					

f.Error Check

- 1) Display
 - No Error

	n	O
--	---	---

- Error

S	1	_
---	---	---

: S1-SENSOR SHORTAGE

- Press SW(△) to check the errors
- Specific errors are below.

g.Ver. Change

- 1) Press SW(▽) - "rEF" -> "FrE"
 - 2) 15sec auto save.
- ※ Re-enter the power plug to confirm change.
(Ver. Change initializes set-up.)

h. °C/°F Change

- 1) Press SW(▼) - F -> C
- 2) 15sec auto save.

i. Cord H/T Change

① Press SW(▼)

- "00" -> "02" -> "04" -> ~ "30" -> "40" -> "100" -> "00"

Display	On	Off	Display	On	Off
"00"	Cord H/T Off		"15"	15min	10min
"02"	2min	10min	"20"	20min	10min
"04"	4min	10min	"25"	25min	10min
"06"	6min	10min	"30"	30min	10min
"08"	8min	10min	"40"	40min	10min
"10"	10min	10min	"100"	Cord H/T on∞	

- Default "10"

② 5sec auto save.

j. LED check & E²PROM clear

- 1) LED blinks 5 times & returns.
- 2) E²PROM Clear & reset.
(set-up °C/°F is remembered.)

k. Vapor Pan ERROR

- ① Hold ▼ & hit △ 5 times to display Vapor Pan enable or disable mode.
- ② Press ▼

	O	N
--	---	---

 ->

O	F	F
---	---	---

③ 15sec auto save

l. Temp. Check Mode.

1) Content

Hold △ & hit ▼ 3 times to enter Mode.

- ① SEGMENT : display value
- ② Operation : Normal Operation

2) Adjustment

① Press ▼

- Display DS -> D-SENSOR Temp. -> RS -> R-SENSOR Temp. -> Return

(REF. : D-Sensor OPEN : tO

D-Sensor SHORT :tS

3) Return

① Press ▼ until Return.

② 20min return after "DS".

m. Condenser Alarm

1) Content

Hold △ & hit ▼ 3 times to enter Mode.

Press △ To Check period..

① SEGMENT :display value

② Operation :Normal Operation

2) Adjustment

① Press △ to adjust period.

0 -> 3 -> 6 -> 9 -> 0 cycle.

0 :Disable

3 : 3 months

6 : 6 months

9 : 9 months

3) Return

① 15sec Return.

n. S1 - Sensor Error

1) S1 - Sensor SHORTAGE or Temp. is over 143°F (62°C)

SEGMENT- "ESH" & Blinks.

2) S1 - Sensor OPEN or Temp. is under -58°F (-50°C)

SEGMENT- "ESL" & Blinks.

3) ERROR Mode Operation.

REF. S1 - Sensor ERROR : 10min On/20min Off

FRE.S1 - Sensor ERROR : 10min On/6min Off

4) If ERROR is removed – Normal Operation.

※ Types of Sensors

No.	Sensor	Description
1	S1 - Sensor	Detected cabinet temperature.
2	D1 - Sensor	Detected Evaporator Coil temperature to defrost system.
3	Rt - Sensor	Detected ambient temperature.

E. Check Error

* Errors will be displayed, if there is no error Display "nO".

NO	Code	Error code	Error explanation	Status of Unit
		DISPLAY		
1	S1-SENSOR (Room Sensor)	S 1	Disconnected Sensor or Room temp is under -58°F	Operate Error mode
		S 1 -	Shortage of Sensor or Room temp is under 149°F	
2	Rt-SENSOR (Ambient sensor)	r t	Disconnected Sensor	Normal Operation
		r t -	Shortage of Sensor	
3	D1-SENSOR (Defrost - Sensor)	D 1	Disconnected Sensor or Room temp is under -58°F	Normal Operation
		D 1 -	Shortage of Sensor or Room temp is under 149°F	
4	Fail to defrost	d F 1	If perform the defrost over 50 min	Normal Operation
5	Fail of Cooling Cycle	C F 1	After pass 30 min from start working , Defrost sensor reached 32°F	Normal Operation
6	Hi temp Frz	E H F	if cabinet temp is keeping 59°F for 8 hr	Normal Operation

7	Hi temp Ref	E H r	if cabinet temp is keeping 45°F for 8 hr	Normal Operation
8	E ² PROM Error	E E P	E ² PROM cannot Read & Write	Normal Operation
9	Open Door	E D r	if Door S/W is open for 1 Hr	Operate Error mode
10	Vapor Pan Error	u F n	Vapor Fan is not connected of error	Normal Operation

When a combined temperature/amperage value is above the limit specified by the compressor manufacturer, a protector will operate independently, turning off the compressor. The compressor will restart when this protector has reset.

Note :

1. Compressor protector resets automatically.
2. If condenser fan is operating and the compressor is off, it is most likely that the protector has operated.

F. Service Diagnosis

a. Diagnosis Chart

Problem	Possible Cause	Remedy	
1. Compress will not start - no current draw.	1. Power Switch	1. "OFF" position.	1. Move to "ON" position.
		2. Loose connection.	2. Tighten.
		3. Failure.	3. Call electrician.
	2. Cord and Plug	1. Defective.	1. Replace.
	3. Ground Fault Circuit interrupter	1. Tripped.	1. Check and reset.
		2. Defective.	2. Replace.
	4. Voltage	1. Too low.	1. Call electrician.
		2. Too hige.	2. Call electrician.
	5. Wiring to Control Board	1. Loose connection.	1. Tighten.
		2. Faulty.	2. Check continuity and replace.
6. Transformer	1. Open coil winding.	1. Check continuity and replace.	
7. Control Board	1. Defective.	1. Replace control board.	
8. Compressor Overload	1. Defective.	1. Replace.	
9. Compressor	1. Open windings.	1. Check continuity and replace.	
10. Relay(Compressor)	1. Bad contacts.	1. Replace.	
	2. Open coil winding.	2. Check and replace.	
2. Compressor will not run - draws current and trips on overload.	1. Voltage	1. Too low.	1. Call electrician.
	2. Start Relay	1. Bad contacts.	1. Replace.
		2. Open coil winding.	2. Replace.
	3. Compressor	1. Locked rotor.	1. Replace.
4. Start Capacitor	1. Defective.	1. Check and replace.	
3. Compressor runs intermittently and trips on overload.	1. Voltage	1. Too low.	1. Call electrician.
		2. Too hige.	2. Call electrician.
	2. Refrigerant Line or Component	1. Plugged or restricted.	1. Clean and replace filter
	3. Condenser Fan Motor	1. Failed.	1. Replace.
	4. Refrigerant	1. Overcharged.	1. Evacuate and recharge
2. Non-condensibile in system		2. Evacuate and recharge	
5. Location of Unit	1. Restricted air flow to	1. Move unit or increase	

		condenser.	ventilation.
4. Cabinet inside temperature too high; compressor will not start	1. Compressor Relay	1. Defective. (115V to relay coil.)	1. Check and replace.
	2. Circuit Board	1. Defective. (Compressor relay coil not energized at 115V.)	1. Replace.

Problem	Possible Cause		Remedy
5. Cabinet temperature too high.	1. Setpoint	1. Incorrect.	1. Correct setpoint. Factory defaults : Freezer -0.4°F(-18°C) Refrigerator 35°F(2°C)
	2. Door	1. Not sealing, or open for long intervals.	1. Check for sealing, check for door open at time of warm cabinet temperature.
	3. Defrost	1. Not enough defrosts occurring per day. Operation in humid conditions.	1. Freezer ; See "C. 1. 5 Defrost System." 2. Refrigerator : "C. 1. 6 Defrost System." 3. Check D-Sensor position.
	4. Refrigerant	1. Leak.	1. Repair leak and recharge
	5. Fan Motor	1. Defective.	1. Check and replace.
	6. Condenser	1. Dirty.	1. Clean.
	7. S1-Sensor	1. Defective.	1. Check and replace.
	8. Control Board	1. Defective.	1. Replace.
6. Cabinet temperature display indicator does not illuminate properly.	1. Board Connection	1. Bad connection between control board and display board.	1. Check connection.
	2. Display Board	1. Defective.	1. Replace.
	3. Control Board	1. Defective.	1. Replace.
7. Cabinet inside temperature too low.	1. Sensor	1. Defective.	1. Check and Replace.
	2. Compressor Relay	1. Defective; contacts welded.	1. Replace.
	3. Circuit Board	1. Defective.	1. Replace.

8. Evaporator does not defrost completely	1. D-Sensor	1. Defective.	1. Check and replace.
	2. Defrost	1. Not enough defrosts occurring per day. Operation in humid conditions.	1. Freezer ; See "C. 1. 5 Defrost System." 2. Refrigerator : "C. 1. 6 Defrost System." 3. Check D-Sensor position.
	3. Defrost Heaters	1. Defective.	1. Freezer : Replace heaters.
	4. Safety Defrost Thermostat	1. Defective, turning off heaters prematurely, or fused open.	1. Freezer : Replace safety defrost thermostat.

Problem	Possible Cause	Remedy	
9. Defrost cycle lasts too long.	1. Defrost Sensor	1. Defective.	1. Replace.
	2. Control Board	1. Defective.	1. Replace.
	3. Defrost	1. Not enough defrosts occurring per day. Operation in humid conditions.	1. Freezer ; See "C. 1. 5 Defrost System." 2. Refrigerator : "C. 1. 6 Defrost System." 3. Check D-Sensor position.
	3. Defrost Heaters	1. Defective.	1. Freezer : Replace heaters.
11. Abnormal noise	4. Safety Defrost Thermostat	1. Defective, turning off heaters prematurely, or fused open.	1. Freezer : Replace safety defrost thermostat.
	1. Fasteners	1. Loose fasteners allow vibration of part.	1. Tighten fasteners.
2. Compressor		1. Problem with mount.	1. Properly mount compressor. Replace any missing grommets.
		2. Floodback to	2. Check for signs of

		compressor.	floodback to compressor. Evacuate and recharge if necessary.
		3. Defective.	3. Replace.
	3. Fan	1. Fan blade loose.	1. Adjust and tighten.
		2. Defective motor.	2. Replace.
	4. Relay	1. Chattering.	1. Replace.

Thermistors (semiconductors) are used for the cabinet control sensor and defrost termination sensor. The resistance varies depending on temperature. No adjustment is required.

If necessary, check for resistance between thermistor leads and visually check the thermistor mounting.

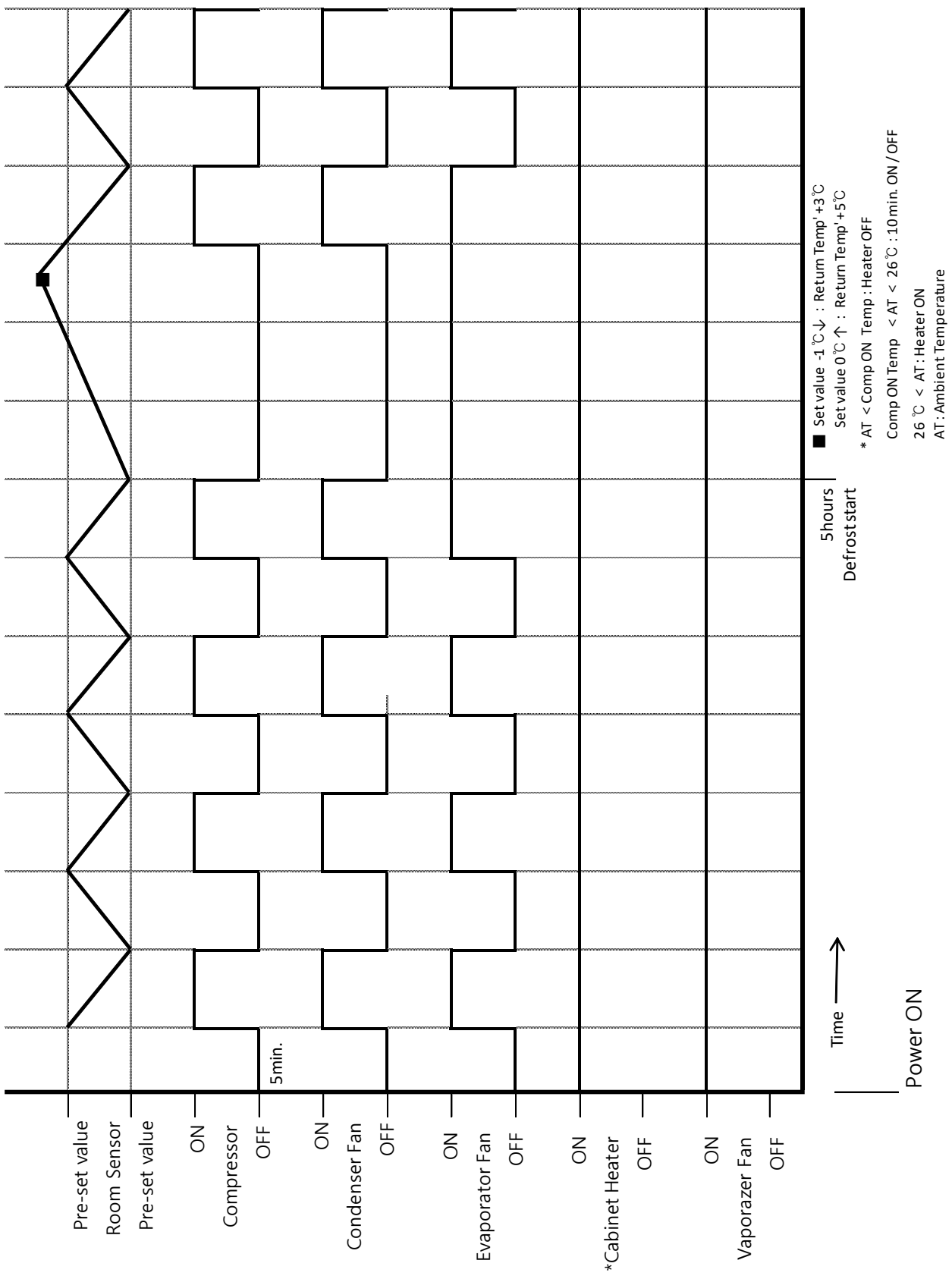

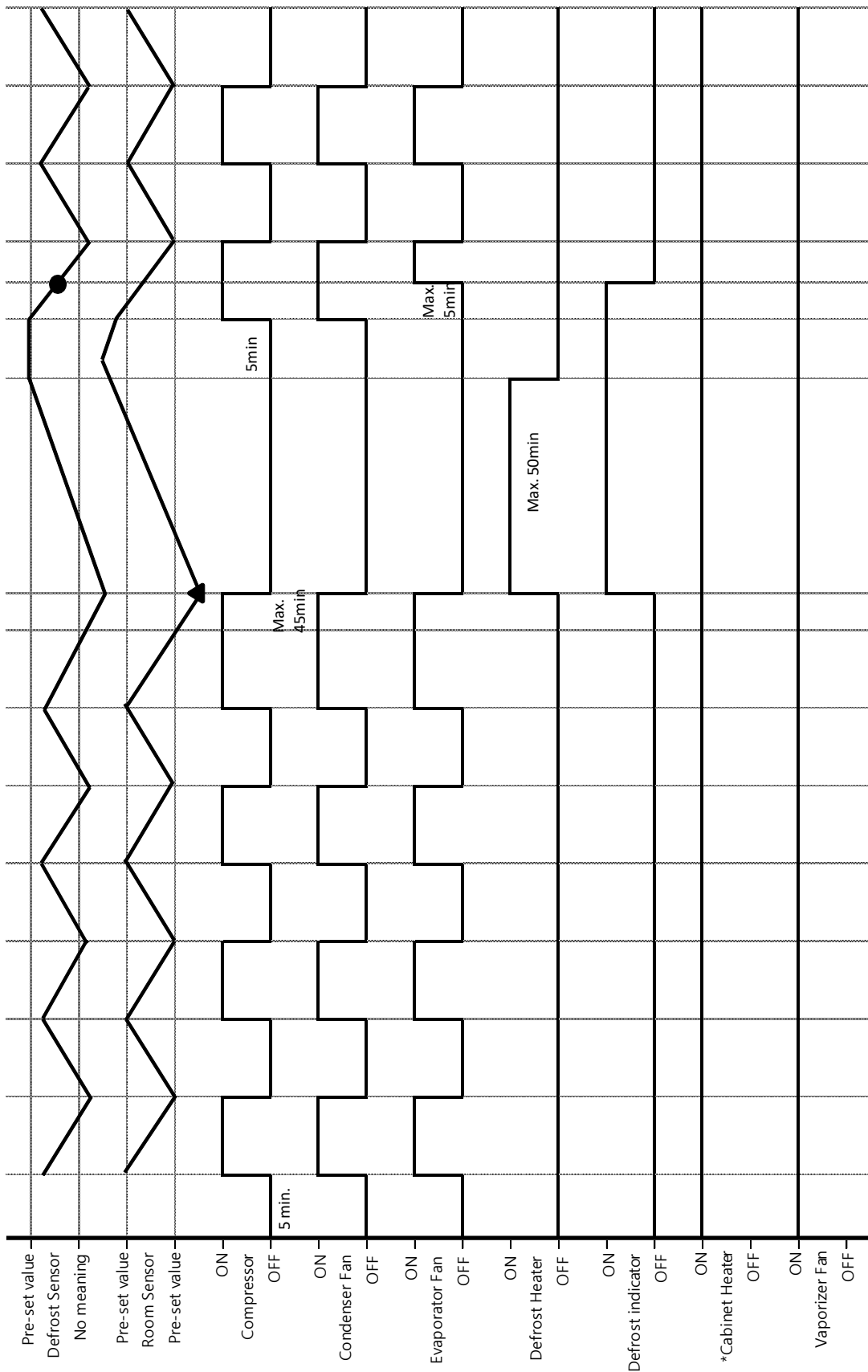

- ▲ Set value minus 8 °C
- Defrost sensor Temp' -10 °C
- * Default setting 8hours, adjustable

Time →
Power ON

G. Error Code

Display	Content	Segment	Function
tO	R-Sensor OPEN	tO	- Comp ON : 6 MINUTES - Comp OFF: 11 MINUTES
ts	R-Sensor SHORT	ts	
	RT-Sensor OPEN/SHORT	Room Temp.	- BOX HEATER 100% On

5. PART LIST_1pg

NO	Code No	Description	NO	Code No	Description
1	R212A-070	CONDENSER WIRE(8)	44	R7439-170	COMPRESSOR (SK1A1Q-L2U)
2	R214A-110	EVAPORATOR REF	45	R7439-620	COMPRESSOR(DK1A3H-L2W)
3	R214A-120	EVAPORATOR FRF	46	R719C-600	HARNESS SENSOR
4	R840A-460	ASSY EVAPORATOR(LNRT_D600)	47	R719C-610	HARNESS MAIN(170)
5	R840A-470	ASSY EVAPORATOR(LNRT 1800_D600)	48	R719C-930	HARNESS DISPLAY
6	R840A-480	ASSY EVAPORATOR(LNFT_D600)	49	R719C-940	HARNESS MAIN(SK182)
7	R840A-270	ASSY EVAPORATOR FRE	50	R719C-950	HARNESS MAIN(DK1A3H)
8	R315A-750	BRACKET MOTOR(TABLE)	51	R719D-050	HARNESS MAIN(SK1A1Q)
9	R315B-060	BRACKET HINGE LOW_L(GLASS)	52	R719D-060	HARNESS MAIN(SC12CLX)
10	R315B-070	BRACKET HINGE LOW_R(GLASS)	53	R720A-740	HEATER EVA(D700)
11	R315B-080	BRACKET HINGE UPP(GLASS)	54	R720A-910	HEATER EVA(D600)
12	R319B-670	PIPE CASE DRAIN(SIDE TABLE)	55	R720A-750	HEATER DRAIN PAN
13	R319B-900	PIPE SUCTION(LNRT)	56	R720A-900	HEATER DRAIN PAN(D600)
14	R319B-910	PIPE SUCTION(LNFT)	57	R725C-210	PCM MAIN(LNRT/LNFT)
15	R319C-350	PIPE SUCTION(LNRT) (D600)	58	R726A-080	MOTOR CONDENSER FAN
16	R319C-360	PIPE SUCTION(LNFT)	59	R726A-090	MOTOR EVA(SIDE TABLE)
17	R319C-370	PIPE SUCTION(SC12CLX)	60	R865A-180	ASSY CONDENSER(F)
18	R333A-050	FAN BLADE EVAP	61	R865A-200	ASSY CONDENSER MOTOR
19	R338A-180	GASKET GLASS DOOR(W900)	62	R817B-860	ASSY DOOR LF(W1200)
20	R338A-190	GASKET GLASS DOOR(W1200)	63	R817B-870	ASSY DOOR LF(W1500)
21	R338A-200	GASKET GLASS DOOR(W1500)	64	R817B-880	ASSY DOOR LF(W1800)
22	R338A-210	GASKET GLASS DOOR(W1800)	65	R817B-890	ASSY DOOR RH(W1200)
23	R364A-030	RAIL_GN	66	R817B-900	ASSY DOOR RH(W1500)
24	R371A-620	SHELF STANDARD(TABLE)	67	R817B-910	ASSY DOOR RH(W1800)
25	R371A-670	SHELF MID(W1800)_GN	68	R817C-160	ASSY DOOR LF(W900)
26	R371A-700	SHELF(W900)_GN	69	R817C-170	ASSY DOOR RH(W900)
27	R371A-730	SHELF(W1200)_GN	70	R817C-230	ASSY GLASS DOOR RH(900)
28	R371A-760	SHELF(W1500)_GN	71	R817C-240	ASSY GLASS DOOR LF(900)
29	R371A-790	SHELF(W1800)_GN	72	R817C-250	ASSY GLASS DOOR RH(1200)
30	R371A-810	SHELF(NRB-90R)	73	R817C-260	ASSY GLASS DOOR LF(1200)
31	R371A-820	SHELF(NRB-120R)	74	R817C-270	ASSY GLASS DOOR RH(1500)
32	R371A-830	SHELF(NRB-150R)	75	R817C-280	ASSY GLASS DOOR LF(1500)
33	R371A-840	SHELF(NRB-180R)	76	R817C-290	ASSY GLASS DOOR RH(1800)
34	R371A-900	SHELF (SALAD 900) (D600)	77	R817C-300	ASSY GLASS DOOR LF(1800)
35	R371A-930	SHELF (SALAD 1800) (D600)	78	R825A-060	ASSY LEG SIDE TABLE(4EA)
36	R3729-010	EVAP FAN BLADE (8 INCH. CCW)	79	R828A-170	ASSY BKT HINGE LOW
37	R714A-030	COMPRESSOR(SC12CLX2)	80	R828A-180	ASSY BKT HINGE UPP
38	R714A-290	COMPRESSOR (SK170H-L2WA)	81	R828A-190	ASSY HINGE LF
39	R714A-340	COMPRESSOR (SK182H-L2UA)	82	R828A-200	ASSY HINGE RH
40	R714A-460	COMPRESSOR(MSA170H-L1G)	83	R828A-270	ASSY BRACKET HINGE LOW LF
41	R714A-510	COMPRESSOR (MSA182H-L2G)	84	R828A-280	ASSY BRACKET HINGE LOW RH
42	R714A-550	COMPRESSOR(MSA190H-L2H)	85	R828A-290	ASSY BRACKET HINGE UPP LF
43	R714A-540	COMPRESSOR(NF21K5131FU)	86	R828A-300	ASSY BRACKET HINGE UPP RH

